



VISIO GAS

INSTALLATION MANUAL (GB)

VISIO 90 RD
VISIO 90 T

RAIS[®]

3rd edition

24th of June 2024

We reserve the right for any typographical errors.

CONTENTS

INTRODUCTION

Introduction to the installation manual	4
The gas fireplace in general	6
Safety	7
Delivery packaging	9
Overview of contents	10

INSTALLATION

Installation guide	12
Installation preparations	13
Removing the glass	14
Mounting the glass	16
Installing the burner	17
Arranging ceramic logs	21
Restrictors	28
Installation of electrical and gas components	29
Electrical connection	30
Gas connection	31
Retractable inspections grate (optional)	32
Remote control	33
Balanced flue system	34
Positioning flue terminals	35
Placement and construction	36
Distance to combustible material	37
Fitting the frame (optional)	42
Starting the gas fireplace	43
Purging the gas pipe	44
Pressure setting adjustment	45
CO and O ₂ measurement	46

MAINTENANCE

Service and maintenance	47
Cleaning	48
Warranty	49

TROUBLESHOOTING AND ERRORS

Troubleshooting	50
Error codes on the remote control	51
Error codes on the app	52

TECHNICAL INFORMATION

Information label	53
Technical data sheets	54
Natural gas	54
LPG	55
Drawings	56

INTRODUCTION TO THE INSTALLATION MANUAL

This gas fireplace must be installed according to this installation manual.

The installation manual covers the following two models:

VISIO 7

Visio 90 RD – Room Divider model (three sides)

Visio 90 T – Tunnel model (two sides)

GENERAL INFORMATION

It is important that the gas fireplace is correctly installed with consideration to the environment and people's safety.

The installation must comply with all local rules and regulations, including those that refer to national and European standards.

REQUIREMENTS

- Learn the structure and content of this manual before installation.
- Pay special attention to the safety chapter and the included manuals.
- Make sure you understand the instructions, otherwise please contact your RAIS dealer.
- Follow the manual completely and in the given structure.

SERIAL NUMBER

The serial number is the gas fireplace's identification number and must be used when making any enquiries relating to the fireplace's warranty.

Find the gas fireplace's serial number on the top left corner of the fireplace and write it down in the text box:

Serial number

See the drawing for the location of the serial number.

Date:	Dealer:
--------------	----------------



Visio 90 RD



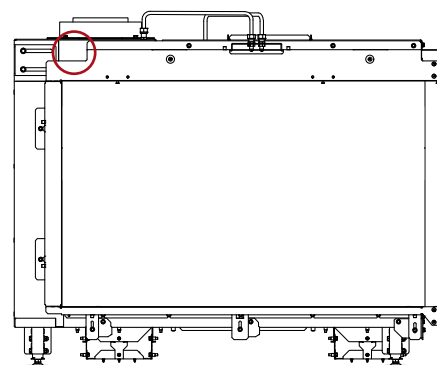

Visio 90 T



Example of serial number

WARNINGS

Please note the symbols below that indicate potentially dangerous situations.

SYMBOL	DESCRIPTION
	Visual sign illustrating an important notice or caution.
	Visual sign illustrating a potential hazard.

INSTRUCTIONS FOR USING QR CODES

You will find QR codes with links to video guides for different installations in several places within the manual.



For using the QR codes, simply open the camera feature on your phone and point it at the code. You will then get the option to open a link to the video guide.

THE GAS FIREPLACE IN GENERAL

This RAIS product is a highly efficient gas fireplace with a sealed combustion chamber for a balanced flue system. The fireplace has variable heating power and is fitted with a burner developed using the latest burner technology.

RAIS gas fireplaces are certified for indoor use, complying with European Standard EN 613. They can be used with ventilation systems and are tested for leak resistance at up to -50 Pa negative pressure. No additional negative pressure monitoring unit or window tilt switch is needed, and there are no specific size or ventilation requirements for the installation room.

BEFORE INSTALLATION

All local regulations and provisions must be studied before installation. Always check the national building and gas regulations.

In addition, it should be confirmed that the description

on the information label relating to gas type and gas pressure is in accordance with the local regulations. The gas supply should be examined to ensure that it can supply the required amount of gas and the required pressure.

It is recommended that gloves are worn when installing the gas fireplace to avoid fingerprints on glass, etc.

GAS CONNECTION

This gas fireplace may only be installed, adjusted, and serviced by an authorised installer. The installation must comply with local and national building and gas regulations, and the instructions in the installation manual must be followed.

KEEP THE MANUALS

The installation manual and user manual are stored by the customer for clarification during use and for, e.g. service.

WARNING!

If you smell gas, immediately switch off the gas supply. Turn off the fireplace at the stopcock and main electrical switch.

Ventilate the room by opening windows and doors. Do not use electrical appliances or switches in the vicinity of the fireplace. The gas supply may not be reconnected until an authorised installer has examined the fireplace and approved it.

NOTE!

For LPG, the installed regulator must allow the inlet pressure given on the information label. An authorised installer must size the pipe to ensure the correct gas pressure and flow rate.

INFORMATION LABEL

All RAIS gas fireplaces have an information label which states the fireplace's gas type, gas pressure, power, etc.

The information label is laid on top of the gas fireplace on delivery. Position the information label with the GV60 Combination Valve and receiver for easy access so that the authorised installer can check the information.

The information label must be used during installation for setting and checking gas pressure.

There is a larger version of the information label on page 53.

18		CE		2575-24		UK CA		0559-24		C11 C31 C91	
Producent af/Produced af/Produkt par/Produktet von - RAIS A/S, Industrivej 20, 9900 Frederikshavn, Denmark											
<input type="checkbox"/> Vialto Gas 70 BD		<input type="checkbox"/> Vialto Gas 90 BD		<input type="checkbox"/> Vialto Gas 101		<input type="checkbox"/> Vialto 100 BD		<input type="checkbox"/> Vialto 101		VY80 6, 7 & 9	
<p>Denne apparat skal installeres i overensstemmelse med gældende regler og kun bruges i et tilstrækkeligt ventileret rum. Foranbruger skal overvåge for installation og brug af dette apparat. Testet og certificeret til brug med biogas og Etanol-tilførselsklasse 1. This appliance must be installed in accordance with the rules in force, and only used in a sufficiently ventilated room. Consult instructions before installation and use of this appliance. Tested and Certified for use on Biogas and Etanol-tilførselsklasse 1. Cet appareil doit être installé conformément aux règles en vigueur et utilisé conformément aux règles d'utilisation validées. Consultez les instructions avant l'installation et l'utilisation de cet appareil. Testé et certifié pour l'utilisation avec du biogaz et la classe d'alimentation E1. Dieses Gerät muss gemäß den geltenden Vorschriften installiert werden und darf für Biogas und/oder Ethanol-tilførselsklasse 1 verwendet werden. Bitte konsultieren Sie die Anweisungen vor der Installation und Verwendung dieses Geräts. Geprüft und zertifiziert für die Verwendung mit Biogas, Energieeffizienzkategorie 1.</p>											
Serialnummer/Serial number/Numéro de série/Serienummer	Brænder ID/Brænder ID/ID du Brûleur/Brænder ID	Destination/land	Input	Output	Mix. Output	Brænder type (kW)	Brænder effekt (kW)	Brænder tryk (bar)	Brænder tryk (bar)	Brænder tryk (bar)	Country of destination
Gas category and supply pressure	Input	Output	Mix. Output	Brænder type (kW)	Brænder effekt (kW)	Brænder tryk (bar)	Brænder tryk (bar)	Brænder tryk (bar)	Brænder tryk (bar)	Brænder tryk (bar)	Country of destination
Catégorie de gaz et pression d'alimentation	Entrée	Sortie	Sortie mix	Pression du brûleur (kPa)	Pression du brûleur (kPa)	Pression du brûleur (kPa)	Pression du brûleur (kPa)	Pression du brûleur (kPa)	Pression du brûleur (kPa)	Pression du brûleur (kPa)	Pays
Gas Kategorie und Versorgungsdruck	Eingang	Ausgang	Mix. Leistung	Brændertryk (kPa)	Brændertryk (kPa)	Brændertryk (kPa)	Brændertryk (kPa)	Brændertryk (kPa)	Brændertryk (kPa)	Brændertryk (kPa)	Land
Gas Kategorie und Versorgungsdruck	Eingang	Ausgang	Mix. Leistung	Brændertryk (kPa)	Brændertryk (kPa)	Brændertryk (kPa)	Brændertryk (kPa)	Brændertryk (kPa)	Brændertryk (kPa)	Brændertryk (kPa)	Land
<input type="checkbox"/> 18	020 20 mbar	0,5	0,5	1,1	0,5	10,7-20,4	0,5	10,7-20,4	0,5	10,7-20,4	DK, DE, ES, FR, GB, GR, IE, IT, NL, NO, PL, PT, SE, SI, SK, UA
<input type="checkbox"/> 18	020 20 mbar	0,5	0,5	1,1	18	10,7-19,0	0,8	7-8,3	0,8	7-8,3	DK
<input type="checkbox"/> 18	020 20 mbar	0,5	0,5	1,1	18,7	10,7-20,4	0,5	10,7-20,4	0,5	10,7-20,4	DK, FR
<input type="checkbox"/> 18	020 20 mbar	0,8	0,8	1,7	22	10,7-24,2	0,8	10,7-24,2	0,8	10,7-24,2	DK, FR
<input type="checkbox"/> 18	020 20 mbar	0,8	0,8	1,7	22	20-24,4	0,8	20-24,4	0,8	20-24,4	DK, FR, IE, IT, NL, NO, PL, PT, SE, SI, SK, UA
<input type="checkbox"/> 18	020 20 mbar	0,8	0,8	1,7	22	20-24,4	0,8	20-24,4	0,8	20-24,4	DK, FR, IE, IT, NL, NO, PL, PT, SE, SI, SK, UA
<input type="checkbox"/> 18	020 20 mbar	0,8	0,8	1,7	22	20-24,4	0,8	20-24,4	0,8	20-24,4	DK, FR, IE, IT, NL, NO, PL, PT, SE, SI, SK, UA
<input type="checkbox"/> 18	020 20 mbar	0,8	0,8	1,7	22	20-24,4	0,8	20-24,4	0,8	20-24,4	DK, FR, IE, IT, NL, NO, PL, PT, SE, SI, SK, UA
<input type="checkbox"/> 18	020 20 mbar	0,8	0,8	1,7	22	20-24,4	0,8	20-24,4	0,8	20-24,4	DK, FR, IE, IT, NL, NO, PL, PT, SE, SI, SK, UA
<input type="checkbox"/> 18	020 20 mbar	0,8	0,8	1,7	22	20-24,4	0,8	20-24,4	0,8	20-24,4	DK, FR, IE, IT, NL, NO, PL, PT, SE, SI, SK, UA
<input type="checkbox"/> 18	020 20 mbar	0,8	0,8	1,7	22	20-24,4	0,8	20-24,4	0,8	20-24,4	DK, FR, IE, IT, NL, NO, PL, PT, SE, SI, SK, UA
<input type="checkbox"/> 18	020 20 mbar	0,8	0,8	1,7	22	20-24,4	0,8	20-24,4	0,8	20-24,4	DK, FR, IE, IT, NL, NO, PL, PT, SE, SI, SK, UA
<input type="checkbox"/> 18	020 20 mbar	0,8	0,8	1,7	22	20-24,4	0,8	20-24,4	0,8	20-24,4	DK, FR, IE, IT, NL, NO, PL, PT, SE, SI, SK, UA
<input type="checkbox"/> 18	020 20 mbar	0,8	0,8	1,7	22	20-24,4	0,8	20-24,4	0,8	20-24,4	DK, FR, IE, IT, NL, NO, PL, PT, SE, SI, SK, UA
<input type="checkbox"/> 18	020 20 mbar	0,8	0,8	1,7	22	20-24,4	0,8	20-24,4	0,8	20-24,4	DK, FR, IE, IT, NL, NO, PL, PT, SE, SI, SK, UA
<input type="checkbox"/> 18	020 20 mbar	0,8	0,8	1,7	22	20-24,4	0,8	20-24,4	0,8	20-24,4	DK, FR, IE, IT, NL, NO, PL, PT, SE, SI, SK, UA
<input type="checkbox"/> 18	020 20 mbar	0,8	0,8	1,7	22	20-24,4	0,8	20-24,4	0,8	20-24,4	DK, FR, IE, IT, NL, NO, PL, PT, SE, SI, SK, UA
<input type="checkbox"/> 18	020 20 mbar	0,8	0,8	1,7	22	20-24,4	0,8	20-24,4	0,8	20-24,4	DK, FR, IE, IT, NL, NO, PL, PT, SE, SI, SK, UA
<input type="checkbox"/> 18	020 20 mbar	0,8	0,8	1,7	22	20-24,4	0,8	20-24,4	0,8	20-24,4	DK, FR, IE, IT, NL, NO, PL, PT, SE, SI, SK, UA
<input type="checkbox"/> 18	020 20 mbar	0,8	0,8	1,7	22	20-24,4	0,8	20-24,4	0,8	20-24,4	DK, FR, IE, IT, NL, NO, PL, PT, SE, SI, SK, UA
<input type="checkbox"/> 18	020 20 mbar	0,8	0,8	1,7	22	20-24,4	0,8	20-24,4	0,8	20-24,4	DK, FR, IE, IT, NL, NO, PL, PT, SE, SI, SK, UA
<input type="checkbox"/> 18	020 20 mbar	0,8	0,8	1,7	22	20-24,4	0,8	20-24,4	0,8	20-24,4	DK, FR, IE, IT, NL, NO, PL, PT, SE, SI, SK, UA
<input type="checkbox"/> 18	020 20 mbar	0,8	0,8	1,7	22	20-24,4	0,8	20-24,4	0,8	20-24,4	DK, FR, IE, IT, NL, NO, PL, PT, SE, SI, SK, UA
<input type="checkbox"/> 18	020 20 mbar	0,8	0,8	1,7	22	20-24,4	0,8	20-24,4	0,8	20-24,4	DK, FR, IE, IT, NL, NO, PL, PT, SE, SI, SK, UA
<input type="checkbox"/> 18	020 20 mbar	0,8	0,8	1,7	22	20-24,4	0,8	20-24,4	0,8	20-24,4	DK, FR, IE, IT, NL, NO, PL, PT, SE, SI, SK, UA
<input type="checkbox"/> 18	020 20 mbar	0,8	0,8	1,7	22	20-24,4	0,8	20-24,4	0,8	20-24,4	DK, FR, IE, IT, NL, NO, PL, PT, SE, SI, SK, UA
<input type="checkbox"/> 18	020 20 mbar	0,8	0,8	1,7	22	20-24,4	0,8	20-24,4	0,8	20-24,4	DK, FR, IE, IT, NL, NO, PL, PT, SE, SI, SK, UA
<input type="checkbox"/> 18	020 20 mbar	0,8	0,8	1,7	22	20-24,4	0,8	20-24,4	0,8	20-24,4	DK, FR, IE, IT, NL, NO, PL, PT, SE, SI, SK, UA
<input type="checkbox"/> 18	020 20 mbar	0,8	0,8	1,7	22	20-24,4	0,8	20-24,4	0,8	20-24,4	DK, FR, IE, IT, NL, NO, PL, PT, SE, SI, SK, UA
<input type="checkbox"/> 18	020 20 mbar	0,8	0,8	1,7	22	20-24,4	0,8	20-24,4	0,8	20-24,4	DK, FR, IE, IT, NL, NO, PL, PT, SE, SI, SK, UA
<input type="checkbox"/> 18	020 20 mbar	0,8	0,8	1,7	22	20-24,4	0,8	20-24,4	0,8	20-24,4	DK, FR, IE, IT, NL, NO, PL, PT, SE, SI, SK, UA
<input type="checkbox"/> 18	020 20 mbar	0,8	0,8	1,7	22	20-24,4	0,8	20-24,4	0,8	20-24,4	DK, FR, IE, IT, NL, NO, PL, PT, SE, SI, SK, UA
<input type="checkbox"/> 18	020 20 mbar	0,8	0,8	1,7	22	20-24,4	0,8	20-24,4	0,8	20-24,4	DK, FR, IE, IT, NL, NO, PL, PT, SE, SI, SK, UA
<input type="checkbox"/> 18	020 20 mbar	0,8	0,8	1,7	22	20-24,4	0,8	20-24,4	0,8	20-24,4	DK, FR, IE, IT, NL, NO, PL, PT, SE, SI, SK, UA
<input type="checkbox"/> 18	020 20 mbar	0,8	0,8	1,7	22	20-24,4	0,8	20-24,4	0,8	20-24,4	DK, FR, IE, IT, NL, NO, PL, PT, SE, SI, SK, UA
<input type="checkbox"/> 18	020 20 mbar	0,8	0,8	1,7	22	20-24,4	0,8	20-24,4	0,8	20-24,4	DK, FR, IE, IT, NL, NO, PL, PT, SE, SI, SK, UA
<input type="checkbox"/> 18	020 20 mbar	0,8	0,8	1,7	22	20-24,4	0,8	20-24,4	0,8	20-24,4	DK, FR, IE, IT, NL, NO, PL, PT, SE, SI, SK, UA
<input type="checkbox"/> 18	020 20 mbar	0,8	0,8	1,7	22	20-24,4	0,8	20-24,4	0,8	20-24,4	DK, FR, IE, IT, NL, NO, PL, PT, SE, SI, SK, UA
<input type="checkbox"/> 18	020 20 mbar	0,8	0,8	1,7	22	20-24,4	0,8	20-24,4	0,8	20-24,4	DK, FR, IE, IT, NL, NO, PL, PT, SE, SI, SK, UA
<input type="checkbox"/> 18	020 20 mbar	0,8	0,8	1,7	22	20-24,4	0,8	20-24,4	0,8	20-24,4	DK, FR, IE, IT, NL, NO, PL, PT, SE, SI, SK, UA
<input type="checkbox"/> 18	020 20 mbar	0,8	0,8	1,7	22	20-24,4	0,8	20-24,4	0,8	20-24,4	DK, FR, IE, IT, NL, NO, PL, PT, SE, SI, SK, UA
<input type="checkbox"/> 18	020 20 mbar	0,8	0,8	1,7	22	20-24,4	0,8	20-24,4	0,8	20-24,4	DK, FR, IE, IT, NL, NO, PL, PT, SE, SI, SK, UA
<input type="checkbox"/> 18	020 20 mbar	0,8	0,8	1,7	22	20-24,4	0,8	20-24,4	0,8	20-24,4	DK, FR, IE, IT, NL, NO, PL, PT, SE, SI, SK, UA
<input type="checkbox"/> 18	020 20 mbar	0,8	0,8	1,7	22	20-24,4	0,8	20-24,4	0,8	20-24,4	DK, FR, IE, IT, NL, NO, PL, PT, SE, SI, SK, UA
<input type="checkbox"/> 18	020 20 mbar	0,8	0,8	1,7	22	20-24,4	0,8	20-24,4	0,8	20-24,4	DK, FR, IE, IT, NL, NO, PL, PT, SE, SI, SK, UA
<input type="checkbox"/> 18	020 20 mbar	0,8	0,8	1,7	22	20-24,4	0,8	20-24,4	0,8	20-24,4	DK, FR, IE, IT, NL, NO, PL, PT, SE, SI, SK, UA
<input type="checkbox"/> 18	020 20 mbar	0,8	0,8	1,7	22	20-24,4	0,8	20-24,4	0,8	20-24,4	DK, FR, IE, IT, NL, NO, PL, PT, SE, SI, SK, UA
<input type="checkbox"/> 18	020 20 mbar	0,8	0,8	1,7	22	20-24,4	0,8	20-24,4	0,8	20-24,4	DK, FR, IE, IT, NL, NO, PL, PT, SE, SI, SK, UA
<input type="checkbox"/> 18	020 20 mbar	0,8	0,8	1,7	22	20-24,4	0,8	20-24,4	0,8	20-24,4	DK, FR, IE, IT, NL, NO, PL, PT, SE, SI, SK, UA
<input type="checkbox"/> 18	020 20 mbar	0,8	0,8	1,7	22	20-24,4	0,8	20-24,4	0,8	20-24,4	DK, FR, IE, IT, NL, NO, PL, PT, SE, SI, SK, UA
<input type="checkbox"/> 18	020 20 mbar	0,8	0,8	1,7	22	20-24,4	0,8	20-24,4	0,8	20-24,4	DK, FR, IE, IT, NL, NO, PL, PT, SE, SI, SK, UA
<input type="checkbox"/> 18	020 20 mbar	0,8	0,8	1,7	22	20-24,4	0,8	20-24,4	0,8	20-24,4	DK, FR, IE, IT, NL, NO, PL, PT, SE, SI, SK, UA
<input type="checkbox"/> 18	020 20 mbar	0,8	0,8	1,7	22	20-24,4	0,8	20-24,4	0,8	20-24,4	DK, FR, IE, IT, NL, NO, PL, PT, SE, SI, SK, UA
<input type="checkbox"/> 18	020 20 mbar	0,8	0,8	1,7	22	20-24,4	0,8	20-24,4	0,8	20-24,4	DK, FR, IE, IT, NL, NO, PL, PT, SE, SI, SK, UA
<input type="checkbox"/> 18	020 20 mbar	0,8	0,8	1,7	22	20-24,4	0,8	20-24,4	0,8	20-24,4	DK, FR, IE, IT, NL, NO, PL, PT, SE, SI, SK, UA
<input type="checkbox"/> 18	020 20 mbar	0,8	0,8	1,7	22	20-24,4	0,8	20-24,4	0,8	20-24,4	DK, FR, IE, IT, NL, NO, PL, PT, SE, SI, SK, UA
<input type="checkbox"/> 18	020 20 mbar	0,8	0,8	1,7	22	20-24,4	0,8	20-24,4	0,8	20-24,4	DK, FR, IE, IT, NL, NO, PL, PT, SE, SI, SK, UA
<input type="checkbox"/> 18	020 20 mbar	0,8	0,8	1,7	22	20-24,4	0,8	20-24,4	0,8	20-24,4	DK, FR, IE, IT, NL, NO, PL, PT, SE, SI, SK, UA
<input type="checkbox"/> 18	020 20 mbar	0,8	0,8	1,7	22	20-24,4	0,8	20-24,4	0,8	20-24,4	DK, FR, IE, IT, NL, NO, PL, PT, SE, SI, SK, UA
<input type="checkbox"/> 18	020 20 mbar	0,8	0,8	1,7	22	20-24,4	0,8	20-24,4	0,8	20-24,4	DK, FR, IE, IT, NL, NO, PL, PT, SE, SI, SK, UA
<input type="checkbox"/> 18	020 20 mbar	0,8	0,8	1,7	22	20-24,4	0,8	20-24,4	0,8	20-24,4	DK, FR, IE, IT, NL, NO, PL, PT, SE, SI, SK, UA
<input type="checkbox"/> 18	020 20 mbar	0,8	0,8	1,7	22	20-24,4	0,8	20-24,4	0,8	20-24,4	DK, FR, IE, IT, NL, NO, PL, PT, SE, SI, SK, UA
<input type="checkbox"/> 18											

SAFETY

It is important that the gas fireplace is correctly installed with consideration to the environment and people's safety. No unauthorised alterations may be made to the fireplace.

The fireplace may not be used if the glass is split, cracked, or removed. Do not use the fireplace if the glass gasket is broken or worn.

Flue systems that are CE approved for this product may be used (see the following balanced flue manual, page 34).

This fireplace is designed for a balanced flue system (air intake and extraction in the same chimney). Therefore,

there is no need for an extra air supply for combustion. It is recommended that the air replacement in the room is adjusted to ensure a pleasant indoor environment.

This fireplace can be installed in an airtight building or in a building with mechanical ventilation since the gas fireplace functions in a closed system that does not affect the indoor climate of the room.

Please be aware that not following the instructions in this manual and the provided manuals can lead to a dangerous or fatal situation.



WARNING!

- The appliance must be positioned and connected as a room sealed system appliance by an authorised installer.
- Before beginning the installation, check that the details on the information label correspond to the gas type and supply pressure to which the appliance will be connected.
- Install the appliance in accordance with the following instructions, and the national and local applicable regulations.
- Do not put flammable or organic material in the fireplace.
- After the fireplace has been shut down, the fireplace needs a cooling period of 15 minutes before the glass can be removed or cleaned.
- Make sure that the area around the fireplace is always free of flammable materials. See minimal safe distance on page 36.
- Make sure that the fireplace stays clean from, e.g. dust and moisture during the installation. Blockage of the delayed ignition flaps can lead to a dangerous situation.
- Make sure that the delayed ignition flaps are functional during installation (see page 43).
- Make sure that the balanced flue is correctly installed.
- Make sure that the GV60 Combination Valve, the piping, and the top of the fireplace remain free of cement or other building materials. Otherwise, this can lead to a leak or defective components.
- Do not twist or force the flexible pipes to the GV60 combination valve. Make sure there is no stress on the pipes.
- Make sure not to damage the pipes during installation or placement of the fireplace.
- Make sure that the compression fittings do not come loose during installation.
- Do not place the fireplace against a flammable rear wall.
- After installation, make sure that the pipes, and compression fittings are gas tight.

SAFETY DEVICES IN THE FIREPLACE

The gas fireplace has three safety devices:

- **1st thermocouple**

Our fireplaces are fitted with a 1st thermocouple in the pilot unit. If the pilot flame is not lit, the fireplace will shut down.

Make sure not to place any decorations around the 2nd thermocouple.

- **2nd thermocouple**

Our fireplaces are fitted with an extra 2nd thermocouple that shuts off the fireplace if the main burner is not lit or is not burning correctly.

Make sure not to place any decorations around the 2nd thermocouple.

- **Delayed ignition flaps**

Our fireplaces are fitted with overpressure doors called delayed ignition flaps. If a hard ignition should occur, the delayed ignition flaps will take the pressure so that the glass is not damaged.

**WARNING!**

- Only use the items that are supplied or described in this manual or other related documents.
- Do not use masking tape on the appliance since it can damage the glass or the paint on the fireplace.
- Do not isolate the fireplace since an airflow around the unit is necessary.
- Do not use fiberglass, rockwool, or any other sort of insulation material as this can create pungent odour and can produce discolouration of the fireplace.
- Make sure that the brick wall or other construction is built with a clearing of at least 3 mm to the fireplace frame.
- There should be a clearance to the side and the back of the fireplace to insure convection. See the distance from page 36.
- Do not build the brick wall higher than the appliance without the necessary support, the fireplace may not be a supporting part of the construction.

**NOTE!**

The fireplace must be installed in fireproofed material. Due to the risk of fire, be aware of the distance to flammable items, e.g. furniture. See the distance from page 36.

This product is a heating appliance. This means that surfaces become very hot and must not be touched when the fireplace is in use or has just been switched off. It is therefore necessary to protect children, seniors and persons with limited mobility from the fireplace.

If the fireplace is switched off or the fire goes out, wait at least three minutes before igniting it again.

DELIVERY PACKAGING

The fireplace is supplied secured to a transport pallet using four transport safety fittings – one in each corner (A). The safety fittings are secured using three screws and these must be removed. The safety fitting can then be removed.

When the fireplace is delivered, please check it for any defects.

The fireplace may not be installed if there is any damage, missing parts, or defects.

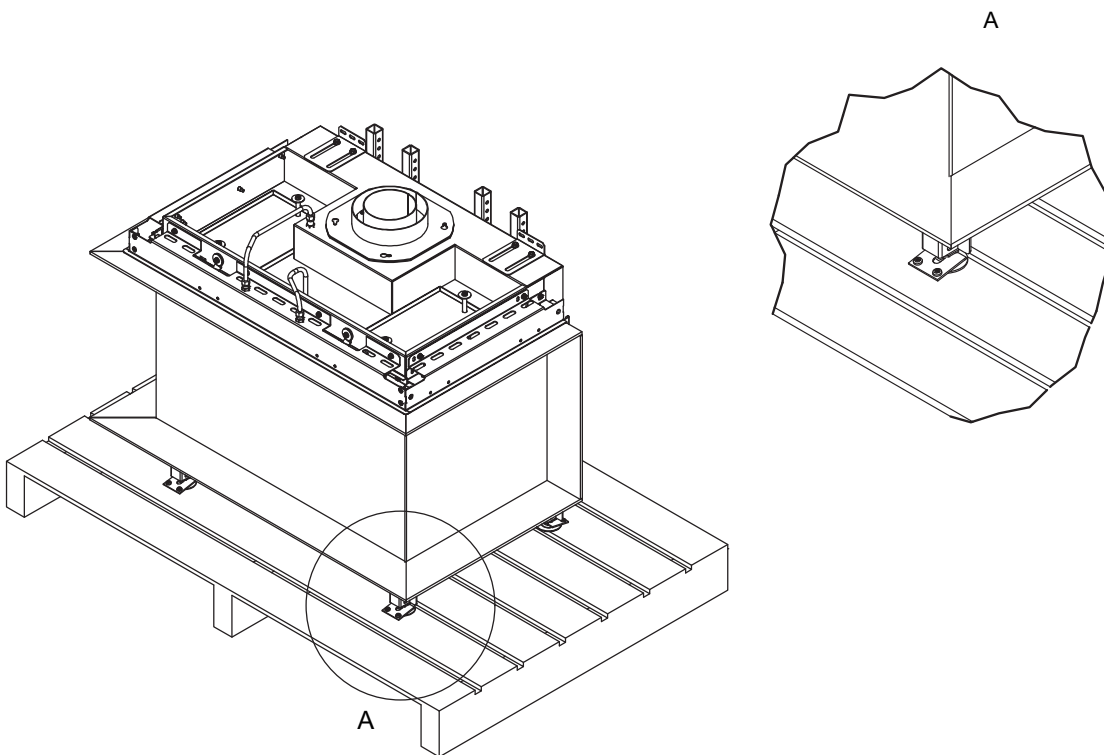

DISPOSAL OF PACKAGING

The fireplace is shipped in packaging that can be recycled. This packaging must be disposed of in accordance with national regulations relating to the disposal of waste.

The glass cannot be recycled.

The glass must be disposed of along with any ceramics or porcelain waste. Heat-resistant glass has a higher melting point and therefore cannot be recycled.

By ensuring heat-resistant glass does not end up alongside recyclable products you are making an important contribution to the environment.

NOTE!

When lifting the fireplace in place, it is important to lift under the fireplace. The fireplace is not designed to be lifted in its top construction or frames



OVERVIEW OF CONTENT

The following elements are included for decoration of the combustion chamber and fine tuning of airflow and flame image:



CONTENTS

1. Logs (qty. 6)
2. Filaments (1 bag)
3. Secondary burners (qty. 2)
4. Restrictors (qty. 3)
5. Ember layer: black, grey (3 bags grey, 3 bags black)
6. Glass (2 bags)

OVERVIEW OF ELECTRONIC COMPONENTS



GV60 combination valve



Receiver



Light module and adapter 12V

OVERVIEW OF REMOTE OPTIONS



Remote control



PUCK (optional)



WiFi module (optional)

INSTALLATION GUIDE

Below is an overview of the following pages regarding the installation of Visio 90 RD and Visio 90 T.

INSTALLATION PREPARATIONS

Follow the recommended instructions on page 13 before starting to install the gas fireplace.

REMOVING THE GLASS

Follow the instructions on page 14 to remove and reinstall the glass.

INSTALLING THE BURNER

Follow the instructions on page 17 to install the burner.

INSTALLING OPTIONAL SOLUTIONS

Follow the separate instructions provided with the respective accessories.

ARRANGING THE CERAMIC LOGS

Follow the instructions on page 21 to arrange the ceramic logs for Visio 90 RD and Visio 90 T.

RESTRICTORS

Follow the instructions on page 28 for the overview and description.

INSTALLATION OF ELECTRICAL AND GAS COMPONENTS

Follow the instructions on page 29 for installing electrical and gas components – including a guide for synchronisation of the remote control and receiver.

BALANCED FLUE SYSTEM

Read an introduction to the balanced flue system on page 34. For a more detailed description and installation, please follow the separate manual for installation manual for the balanced flue system.

PLACEMENT AND CONSTRUCTION

Follow the instructions on page 36 for placement requirements and distance from combustible material.

MOUNTING THE GLASS

Follow the instructions on page 16 to reinstall the glass.

STARTING THE GAS FIREPLACE

Follow the instructions on page 43 when igniting the fireplace for the first time.

PURGING THE GAS PIPE

Follow the instructions on page 44 for a functional test to check the function for starting the gas fireplace.

PRESSURE SETTING ADJUSTMENT

Follow the instructions on page 45 for a pressure test.

CO AND O₂ MEASUREMENT

Follow the instructions on page 46.

INSTALLATION PREPARATIONS

On this page, we have listed points to be aware of before starting the installation of the gas fireplace.



NOTE!

Placement and construction preparations

- If the installation is made in an existing chimney, clean the chimney before installation.
- Install the fireplace on a solid floor that can hold the weight of the fireplace.
- When building the fireplace, make sure to install ventilation beneath and above the fireplace for a natural draught. This will prevent high temperatures that can damage the installation or fireplace.
- Never use combustible building materials.
- Do not install the fireplace against a flammable rear wall.
- Protect the ceiling if it is made of flammable material.
- Comply to the fireproof distances stated in this manual. See the exact distances on page 36.
- When the fireplace has been placed, make sure it is level and straight.
- The glass on the fireplace needs to be cleaned before using it the first time, otherwise fingerprints, etc., can burn to the glass.

Preparations for electrical and gas supply

- The gas supply and electrical supply should be located under the fireplace in the area where the inspection grate will be installed. We recommend installing the gas supply with a flexible approved system.
- The electrical parts should always be accessible.
- Make sure to calculate the right diameter for the gas supply for correct function of the fireplace.

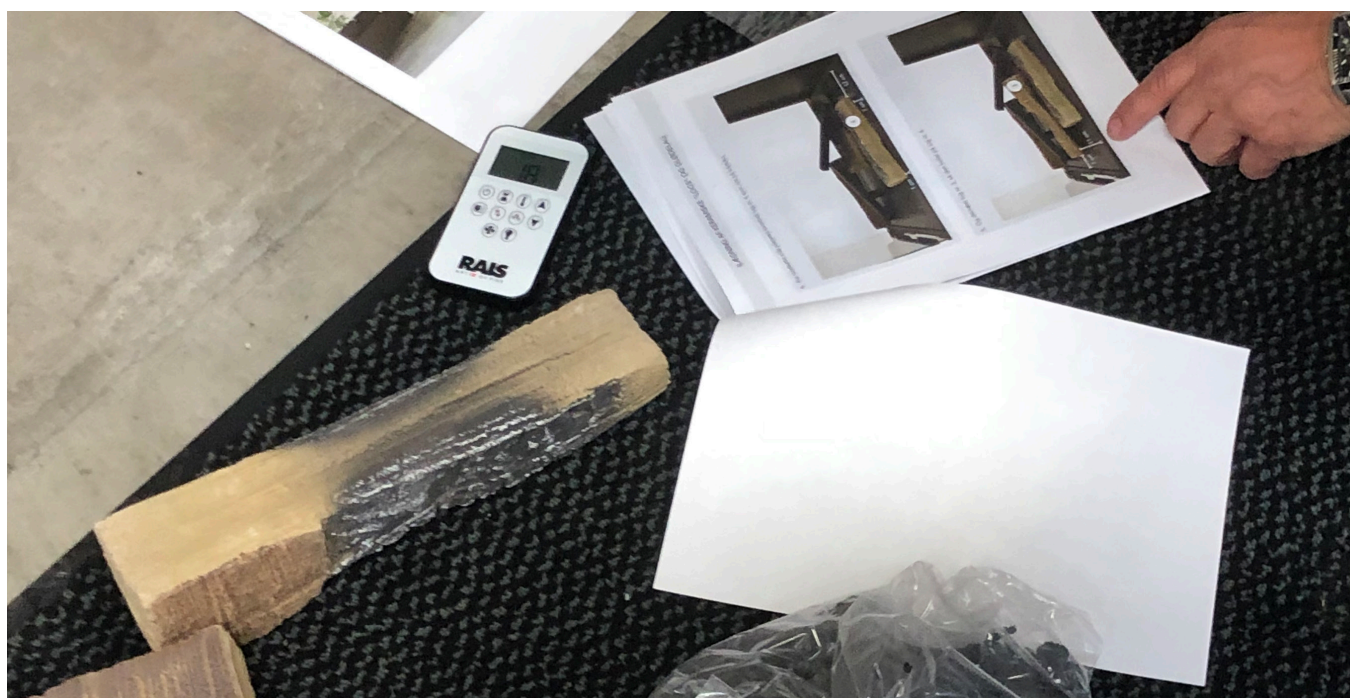

REMOVING THE GLASS

The gas fireplace comes with the glass fitted. The glass must be removed to install the fireplace burner.

The frames must be removed before removing the glass.

REMOVING THE GLASS

Scan the QR code to watch a how-to-video



NOTE!

Glass edges are sensitive. Be careful while working with the glass. For the room divider model, only remove one of the side glass. The small glass is a part of the construction and may not be removed.

We recommend to use gloves when handling the glass.

If the glass is anti-reflected, suction cups must not be used. See page 48 about cleaning.



1. Find the two rotary flaps at the top of each side of the fireplace glass (see the arrows).



2. Turn the two rotary flaps anticlockwise until they are free of the glass.



3. Grip the two metal edges on the glass and pull the glass towards the front.



4. Lift the glass until it is free of the base frame. Tilt the bottom of the glass out and then down.



5. The glass can now be removed.



MOUNTING THE GLASS

When the glass is to be reinstalled, please follow the installation guide "Removing the glass" on page 14 by starting with the last step and be aware of the position indicator shown below.

NOTE!

There is a position indicator in the middle of the gas fireplace frame, which ensures the glass is fitted correctly. This wedge must fit between the two notches on the glass. It is very important that this is done correctly, otherwise the fireplace will not close properly and soot may form during use. See the procedure below.

Incorrect installation of the glass can lead to a dangerous situation.



PROCEDURE

1. The position indicator is positioned in the top of the fireplace frame (see the arrow).

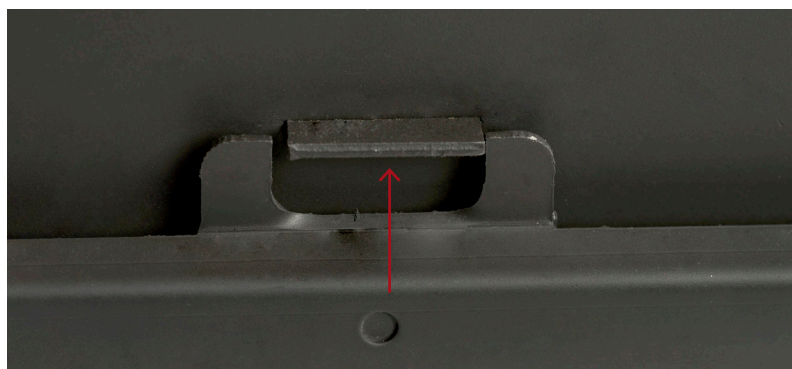

The photo shows the fireplace without the frame.

2. Carefully move the glass from side to side, until you can feel the glass engage with the position indicator (see the arrow).

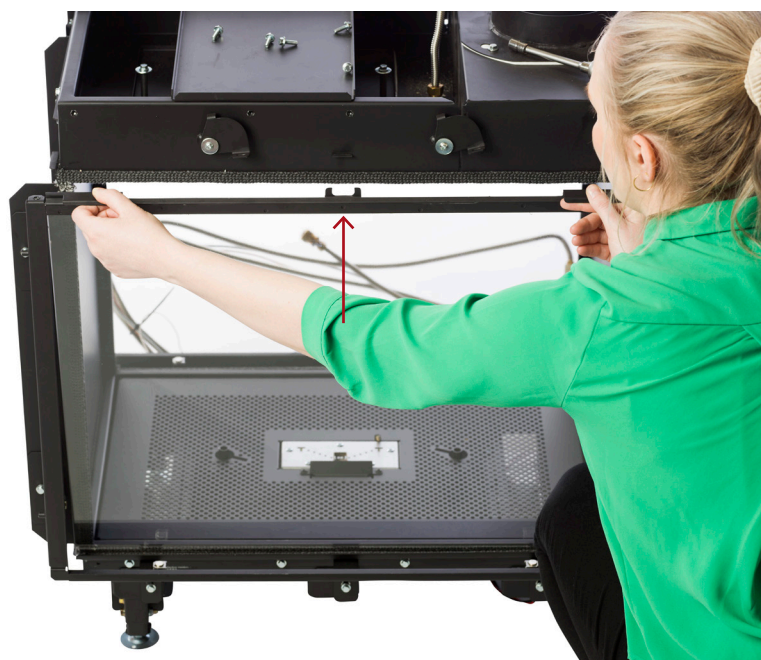

INSTALLING THE BURNER

If the burner is not installed on delivery, please follow these steps to fit the burner.

Make sure that the burner fits the required gas type. The gas type for the burner is described on the side of the box which it arrives in. Check that the injectors correspond to gas type and that the air settings are correct.

AIR SETTINGS FOR NATURAL GAS

The airplate for the main burner needs to be set on half (see the arrow).

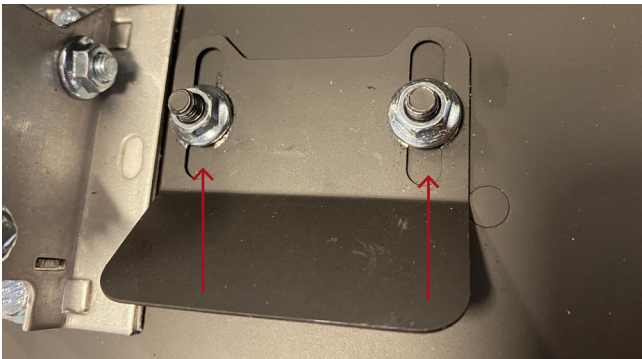

AIR SETTINGS FOR LPG

The airplate for the main burner needs to be set on fully open (see the arrows).

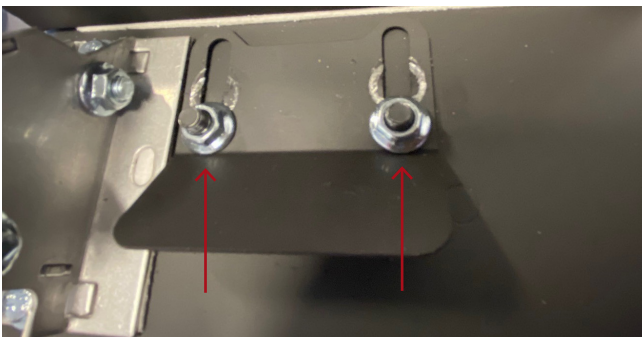

The air settings for the burners varies between the gas types. Make sure that the correct air settings have been made, if not, please make the necessary adjustments.

Follow the guide below for air setting natural gas or LPG.

The venturis for the secondary burners needs to be fitted with a two covering plates. One full plate and one plate with a small hole.



The venturis for the secondary burners needs to be fully open with no covering plates installed.



PROCEDURE

1. Remove the burner and hose from the box.



2. Remove the bottom grate from the combustion chamber.



3. Remove the four fitted bolts on the bottom of the fireplace (see the arrows).

**WARNING!**

Incorrect installation can cause a dangerous situation. Make sure that the bottom bolts are tightened and that the burner is pressed against the bottom combustion chamber gasket.



- Fit the burner in the combustion chamber using the four screws. Check that the gasket between the burner and the fireplace base is intact. The burner must be mounted with the pilot flame towards the front of the appliance.

If the exhaust is to the right (see the red circle), the pilot is in front.

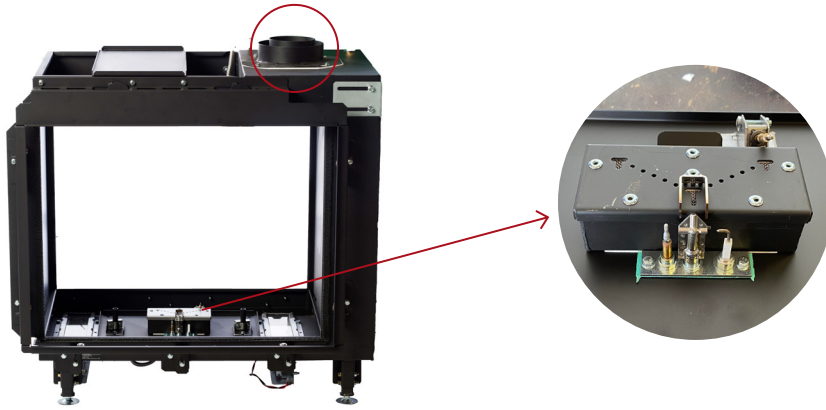

- Now pull the GV60 Combination Valve, pipe and receiver towards the side where the inspection grate is desired to be positioned. No further than 500 mm from the middle of the fireplace.

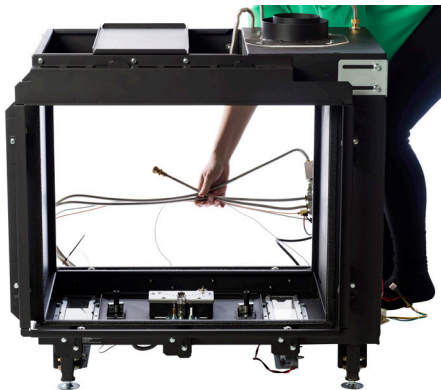

- Position the bottom grate above the burner.



OVERVIEW OF THE BURNERS

GB



Main burner

Secondary burner

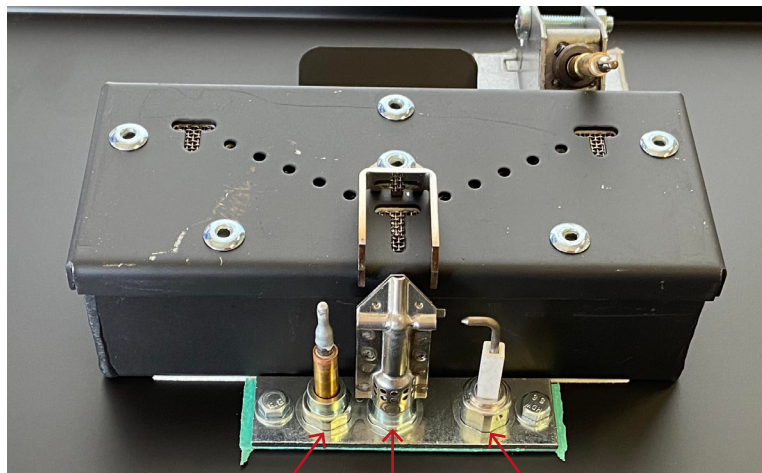

1st thermocouple

Pilot flame guide

Piezo electrode

ARRANGING THE CERAMIC LOGS

When arranging the ceramic logs and the embers layer in the combustion chamber, it is important that they do not cover the pilot flame and its thermocouple, and ember material must not be placed under the pilot guard.

Both thermocouples must be kept free of the embers layer. Do not cover the holes in the main burner (see the circles).

When commissioning or servicing the fireplace, it must be ensured that the cross ignition (from the pilot flame to the main burner) functions, and that ignition occurs easily with the secondary burners.

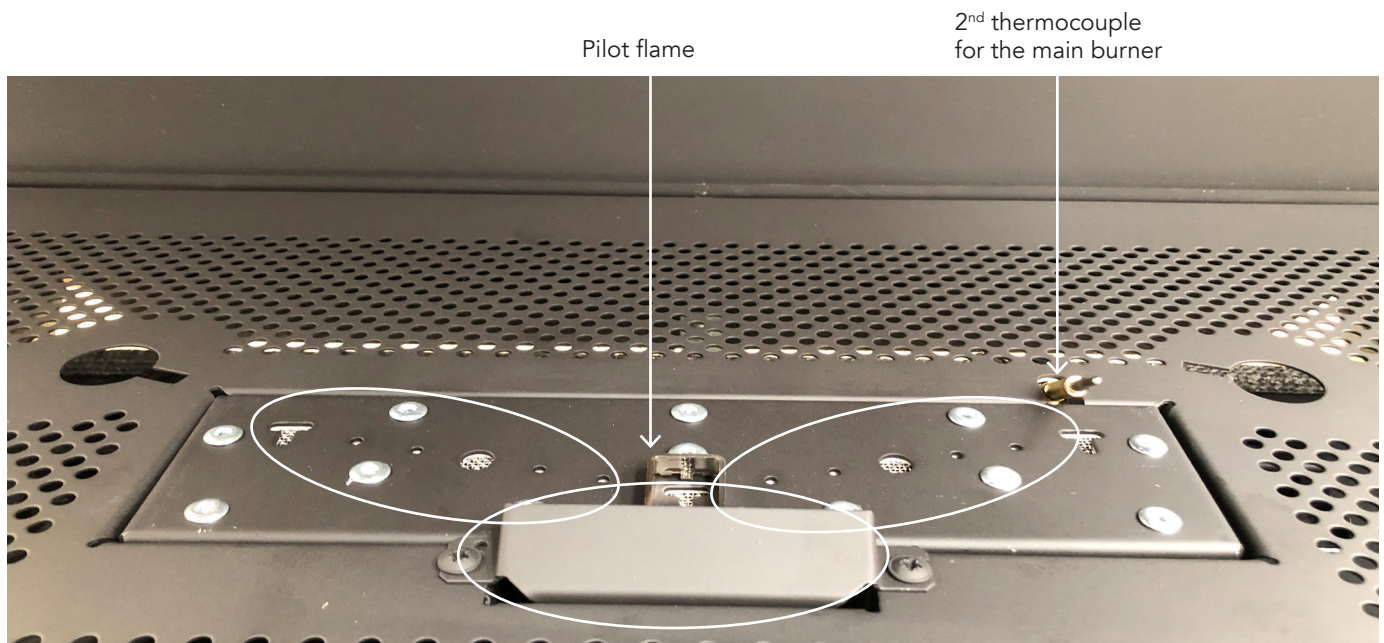

WARNING!

It is very important that you follow this manual when positioning ceramic logs and the embers layer in the fireplace. Failure to carry this out correctly will result in a flame profile that is less than optimal. Incorrect placement of the logs can lead to a dangerous situation.



NOTE!

The measurements on the following photos are taken **from the edge of the base plate**. See photo below.

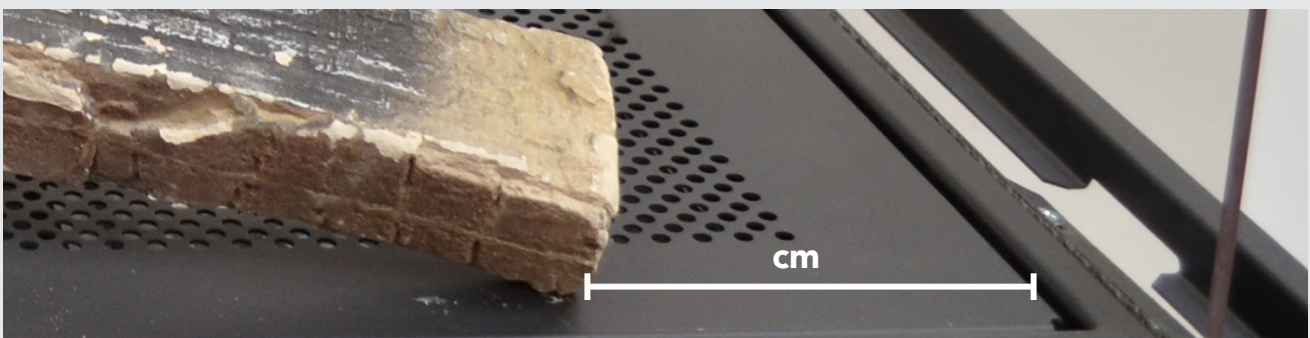

LOG PLACEMENT – VISIO 90 RD AND VISIO 90 T

The following ceramic logs must be used.

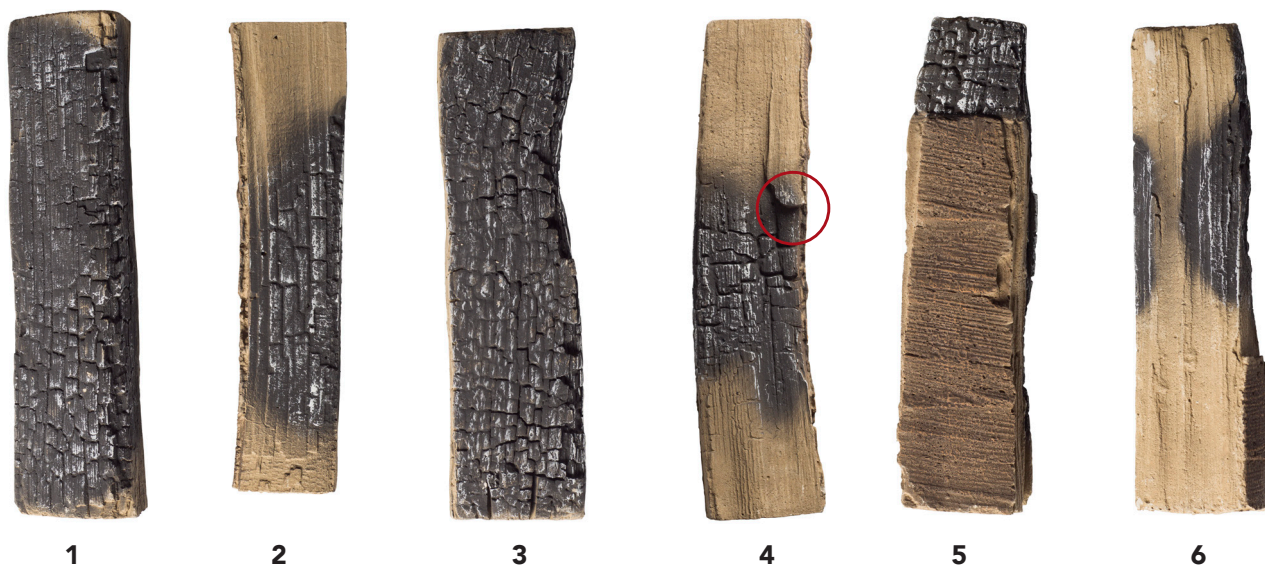

A small elevation
in log no. 4
can be used for
identification

1. Start by securing the two secondary burners in the fireplace's base plate.



NOTE!

The tip of the secondary burners must be twisted as far from each other as possible.



2. Start from the opposite side of the pilot flame – see the photo on the previous page. Place ceramic log no. 1.



3. Then place ceramic log no. 2. Now the remaining logs must be put in from the opposite side. Therefore, go over to the same side as the pilot flame.



4. From the opposite side, place ceramic log no. 3.



5. Place log no. 4, so that it rests on log no. 3.



6. Now the glass pieces must be distributed in the burning chamber. Measure 5 dl of glass into a measuring cup.



7. Distribute the glass pieces (5 dl in total) on both sides of the gas fireplace – over the LED lights. It is important that the pieces of glass are distributed in a thin layer that just exactly covers the holes in the bottom of the fireplace.



8. Now measure 2.5 L of the ember chips (a mixture of the grey and the black chips).



9. Sprinkle the ember chips over both the glass pieces and the rest of the base plate. Place the filament on the bottom burner.



WARNING!

Be aware that the main burner and pilot flame are kept free of all ornaments.

10. Place the filament on the main burner for an extra glowing effect.
The filament must not get in contact with the thermocouples – use the chips to secure the filaments.



11. Place ceramic log no. 5 on the secondary burner to the right.



12. Place ceramic log no. 6 on the secondary burner to the left.



RESTRICTORS

Three different restrictor are included for the gas fireplace. The restrictors are used to create the correct flow in the balanced flue.

It is important to see and assess from the flame picture whether the correct restrictor is fitted.

The flames should be blue/yellow at start-up, after 20 minutes the flames should be a clear yellow. If the desired combustion is not achieved, another restrictor can be installed.

The restrictors come in 3 different sizes:

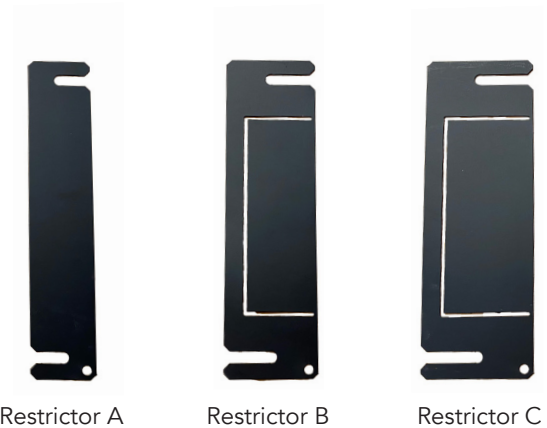

RESTRICTORS	
Vertical height up to 2 m	Restrictor A
Vertical height up to 2-4 m	Restrictor B
Vertical height up to 4-7 m	Restrictor C
Vertical height up to 7-10 m	Restrictor B
Vertical height up to 10-15 m	Restrictor A



1. Loosen two of the bolts diagonally.



2. Mount the restrictor according to the form, and then tighten the two bolts diagonally.

INSTALLATION OF ELECTRICAL AND GAS COMPONENTS

CONNECTION DIAGRAM

Use the diagram to get an overview of the individual electrical and gas components. Pictures of the parts will be provided on the following pages.

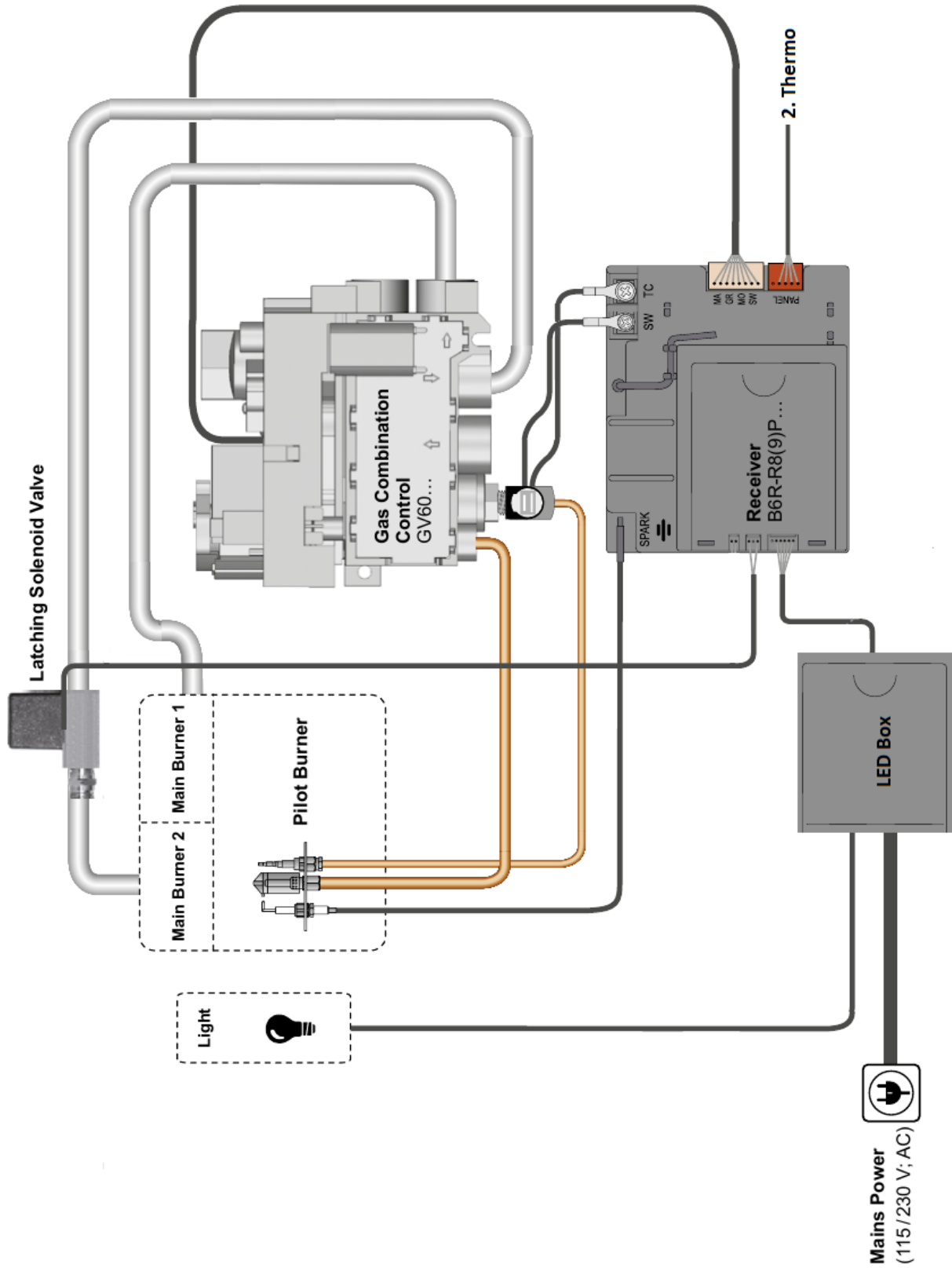

ELECTRICAL CONNECTION

The following electrical parts accompany this gas fireplace:



LED box



Power supply/
adapter 12V



Receiver

CONNECTING THE LED BOX

The LED box must be connected to the power supply (see arrow A).

The LED box can be positioned on the retractable inspection grate (optional).

CONNECTING THE RECEIVER

The wide yellow/blue/green connector on the LED box must be inserted in the receiver (see arrow B).

If there is a power failure, four AA batteries can be fitted in the receiver. If batteries are used in the receiver, the LED light and WiFi module will not operate.

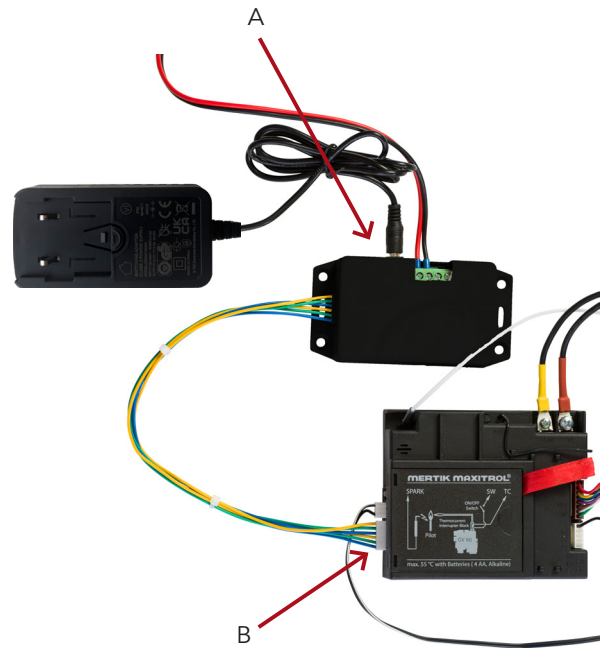

WARNING!

The power supply (12V adapter) may NOT be directly connected to the receiver, otherwise this could lead to overheating and functional failure.

Sockets must always be accessible.

Make sure that the electrical cables do not touch the fireplace or are placed higher than the fireplace if within 1 metre of the fireplace.

If batteries are used in the receiver, replace the batteries at the beginning of each heating season.

GAS CONNECTION

PROCEDURE

1. Remove the strips holding the flexible gas lines and wires together and place the parts carefully under the fireplace. Make sure that no cables are disconnected.
2. Connect your gas supply to the GV60 Combination Valve's flexible inlet line. The thread on the GV60 Combination Valve is 12 mm 3/8'.

Secure against leaks in all gas connections made. Make sure that the gas is correctly connected.

Always install a stopcock and a measuring stud before the GV60 Combination Valve. The stopcock should be placed closest to the GV60 Combination Valve.

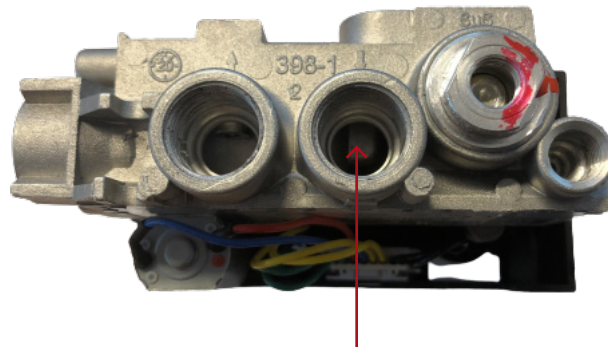
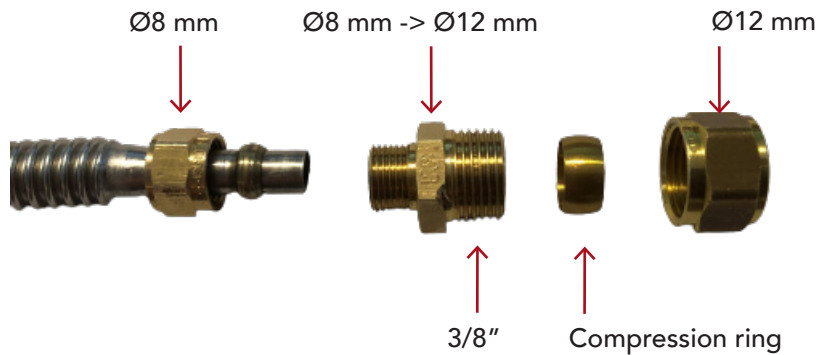

Ø12 mm 3/8" gas inlet – Only if the flexible line is not used

WARNING!

Do not twist or hard bend the flexible gas lines from the GV60 Combination Valve. Make sure that the flexible gas lines are not stressed, and not to damage the gas lines or couplings on the GV60 Combination Valve.



RETRACTABLE INSPECTION GRATE (OPTIONAL)

As an accessory for the built-in gas fireplaces, a retractable inspection grate is available. The retractable grate covers the GV60 Combination Valve, receiver, etc., and can easily be pulled out during, e.g. service and maintenance. The inspection grate also functions as a convention grate.

**RETRACTABLE
INSPECTION GRATE**
Scan the QR code
to watch a how-to-video



The retractable inspection grate is available in two different sizes:



Small inspection grate – front
60 cm²



Small inspection grate – inside



Large inspection grate – front
200 cm²

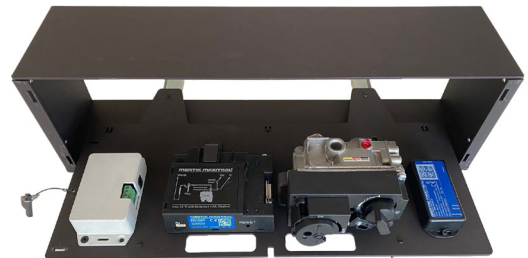

Large inspection grate – inside

REMOTE CONTROL

In this section you can learn how to set up the remote control for the gas fireplace.

The remote control uses 2 x AAA 1.5V batteries.

Never use pointed tools to remove the batteries from the receiver and remote control.

The signal range between the remote control and the gas fireplace must not exceed 10 metres.



NOTE!

Once a year you should replace the batteries in the remote to ensure optimal operation. Replace all the batteries at the same time and use only good quality alkaline batteries.

SYNCHRONISE THE REMOTE CONTROL

Scan the QR code to watch a how-to-video



SYNCHRONISATION OF THE REMOTE CONTROL AND RECEIVER

1. Press and hold the receiver's "reset" button until you hear a short 'beep' followed by a long 'beep' (see the arrow).
2. After the second beep, release the reset button. You now have 20 seconds to press the "down arrow" button on the remote control. Hold the button in, until you see the word "conn" on the remote control. Then release the button.
3. The remote will then count to 8 and two short beeps will sound from the receiver. The receiver and remote control are now synchronised, and the fireplace can be lit.

See the separate User Manual for remote control options and a guide for the PUCK.



Remote control



Receiver



USER MANUAL

Scan the QR code to see the user manual

BALANCED FLUE SYSTEM

BALANCED FLUE SYSTEM

Scan the QR code to see a guide online



The flue system is what makes the fireplace function. The fireplace will not function optimally if it does not have the correct and necessary flow in the flue system.

Please consult national/local regulations before installing the flue system. It must be ensured that the flue terminal's position is in accordance with national building regulations.

This fireplace may be installed with either a roof terminal (C31), a wall terminal (C11), or a flexible system through an existing chimney (C91). The fireplace may only be installed using a balanced flue (also known as balanced flue system) in the way stated by RAIS . The RAIS fireplace is approved with the Exodraft fan system.

The flue pipes recommended by RAIS have been approved together with the fireplace and the fireplace may only be installed using these:

MANUFACTURER	SYSTEM	ADAPTER	FLUE SIZE	FLUE TYPE
Schiedel	Metalotherm US system	No adapter needed	Ø130/200	Natural Draught
Schiedel	Metalotherm USD system	No adapter needed	Ø130/200	Natural Draught
Müllink & Grol	Multi-Vent system	Adapter needed	Ø130/200	Natural Draught
Poujoulat	DUOGAS system	Adapter needed	Ø130/200	Natural Draught
Jeremias	TWIN-GAS system	Adapter needed	Ø130/200	Natural Draught
Exodraft	RHGC	No adapter needed	Ø100/150	Forced Draught

The joints on the flue pipes must be sealed and secured against separation using locking bands or screws.

The fireplace is supplied with a spigot prepared for the interior fitting of a flue pipe with a diameter of 130/200 mm.

The safety distance from the flue pipe to flammable materials must be at least 50 mm.

When using a wall outlet, always go straight up 0.5 metres before introducing a 90-degree bend. Please follow the instructions in the balanced flue manual.

For installation instructions for the flue system, please follow the separate manual for installation of the balanced flue. Scan the QR code at the top of the page to read the manual online.

POSITIONING FLUE TERMINALS

The table below shows how different flue terminals can be positioned in the house and how large the safety distances must be.

NOTE! Be aware that the safety distances below are English national guides. Please follow national regulatory requirements.



GB

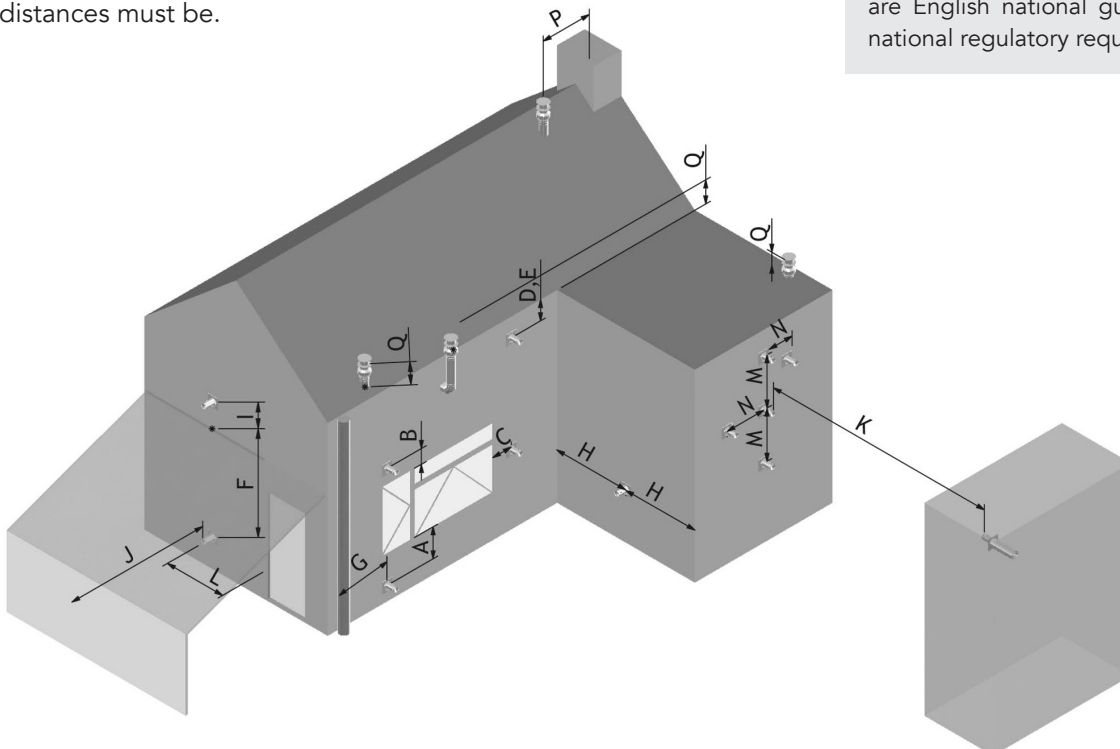

DIMENSIONS	TERMINAL POSITION	DISTANCE (mm)
A*	Directly below an opening, ventilation, opening window, etc.	600
B	Above an opening, ventilation, opening window, etc.	300
C	Adjacent to an opening, ventilation, opening window, etc.	400
D	Below gutters, soil pipes or drainpipes	300
E	Below eaves	300
F	Below balconies of car port roof	600
G	From a vertical drainpipe or soil pipe	300
H	From an internal or external corner	600
I	Above ground roof or balcony level	300
J	From a surface facing the terminal	600
K	From a terminal facing the terminal	600
L	From an opening in the car port (e.g. door, window into the dwelling)	1200
M	Vertically from a terminal on the same wall	1500
N	Horizontally from a terminal on the same wall	300
P	From a vertical structure on the roof	600
Q	Above an intersection with the roof	150

* In addition, the terminal should not be nearer than 300 mm to an opening in the building fabric formed for the purpose of accommodating a built in element such as a window frame.

PLACEMENT AND CONSTRUCTION

Use insulation panels with a maximum thermal conductivity of 0.10 W/m.K or a minimum thermal resistance of 10 K.m/W. Suitable products can be Promat Promatect L insulation board, Skamol Skamotec 225, or Skamol Super-Isol.

The receiver and GV60 valve are connected to the burners in the fireplace. It should be placed in the inspection grate, which should be positioned appropriately below the fireplace.

The receiver and the GV60 Valve are connected to the fireplace's burners. This must be placed in the inspection grate, which must be placed in an appropriate place under the fireplace.

Small adjustments of the legs are possible using the feet, and these should be set to the desired height before the flue system is installed. Never make any changes to the fireplace other than adjusting the height of the legs. In addition, tall legs are optional.

The fitted brackets are used to secure the fireplace to the rear wall.

Two measuring points are positioned above the glass and are used to carry out combustion checks. On the left, fresh air in, on the right, exhaust air. See the illustrations on page 46.

In cases where national regulations require that control measurements are taken in the flue pipe and above the fireplace, a measuring spigot can be positioned here.

Make sure that the fireplace is completely insulated from combustible materials on all sides. We recommend protecting the ceiling and floor with non-combustible material inside the build-up. Always keep the specified safety distances for your fireplace to combustible materials.

Build a structure of the desired size made from non-combustible materials – the minimum dimension for each model is shown in the following section.

Do not use insulated material (or other material) to fill the cavity above and at the side of the fireplace.

CONVECTION

The installation space must be fitted with convection openings which have a minimum area of 200 cm² above the fireplace and 200 cm² below the fireplace.

The convection above the fireplace should keep a 300 mm distance to the ceiling.

NOTE!

The 1000 mm upwards is a minimum distance to a combustible ceiling. Always keep min. 3 mm from building material to the fireplace due to heat expansion.

Do not place any combustible materials inside the build-up.

Make sure that the ventilation gets a free flow around the fireplace. There should be free space of at least 50 mm around the entire fireplace to allow for convection.

The receiver and the GV60 Combustible Valve should be positioned underneath the fireplace.

We recommend to always mount and test the fireplace before finishing the build-up.

It must be possible to remove the frames, therefore do not mount them with silicone or similar.



DISTANCE TO COMBUSTIBLE MATERIAL

FRONT AND SIDE VIEW

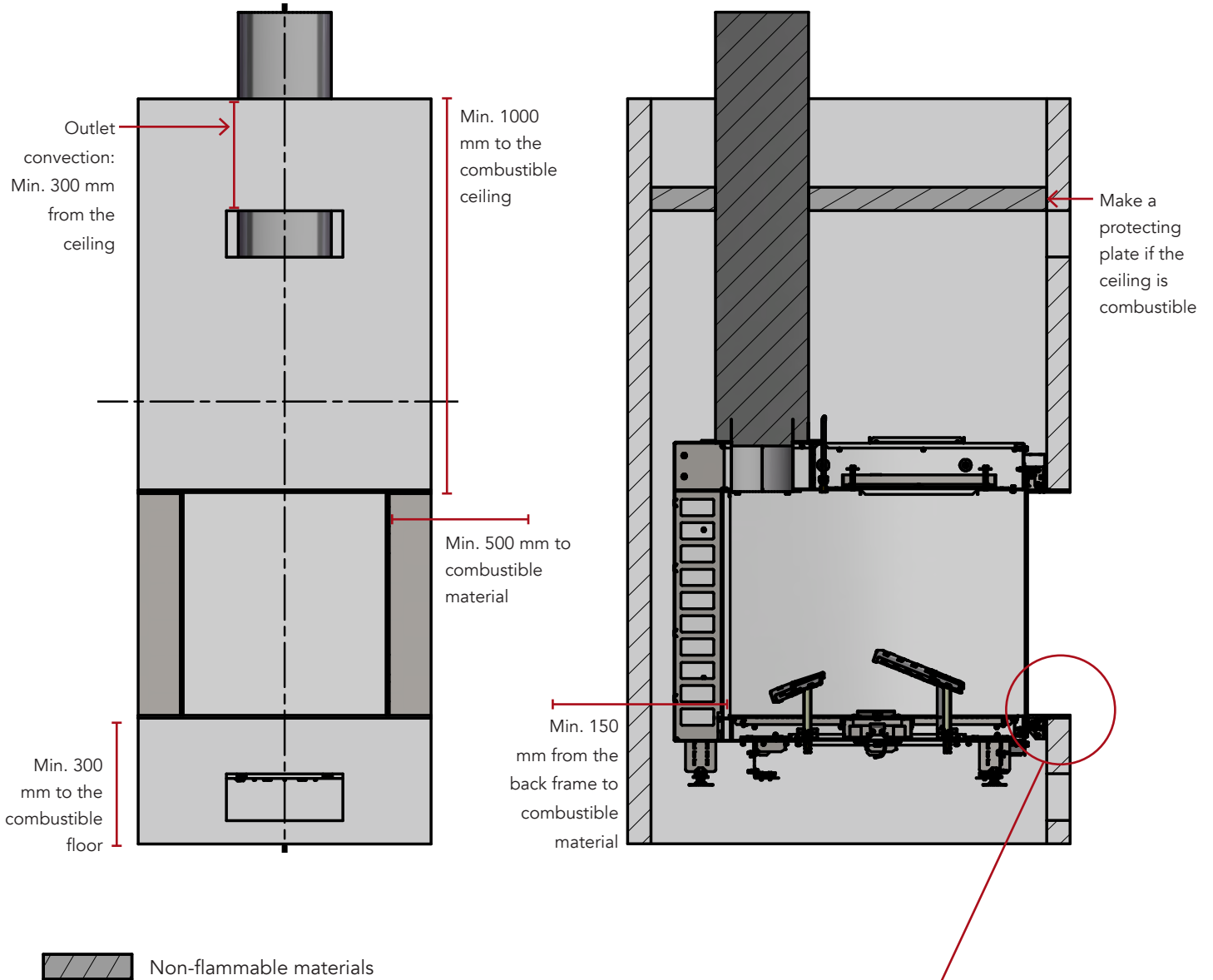

NOTE!
 When plastering a wall, remember to free up the required millimetres for the frame during construction to get a smooth final finish.



TOP VIEW

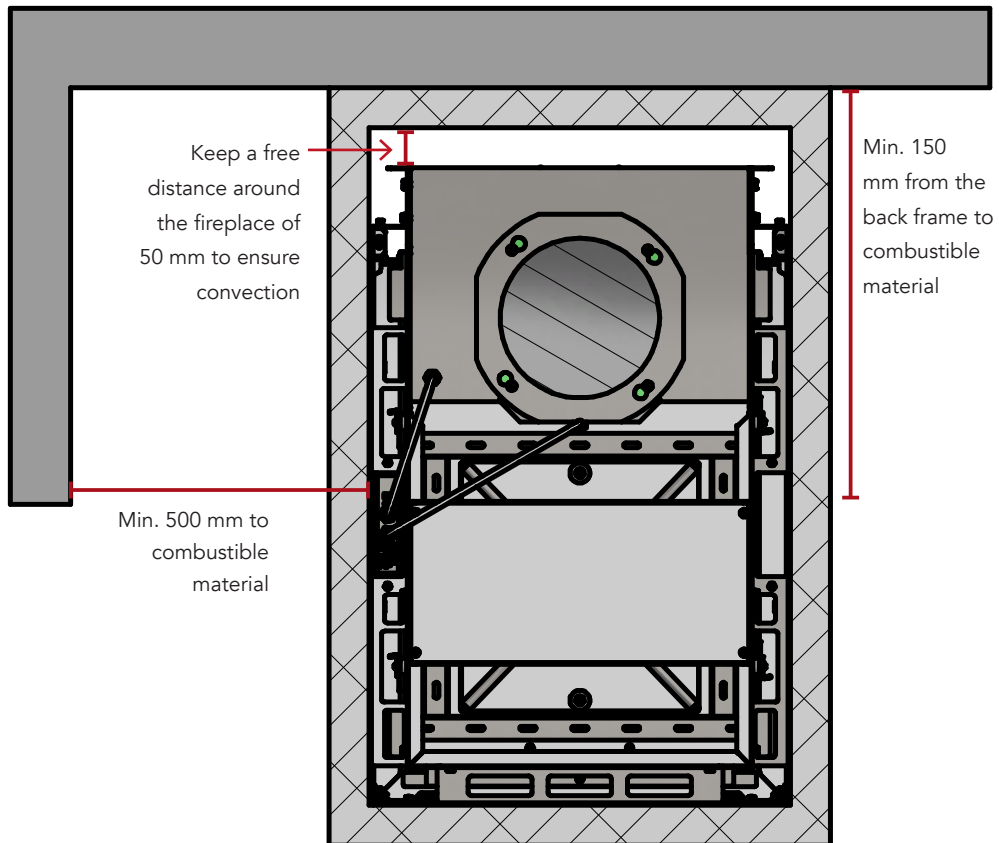

Combustible material



Non-flammable material

DISTANCE TO THE COMBUSTIBLE SHELF

If you want to position flammable material above your fireplace, you must follow these minimum requirements.

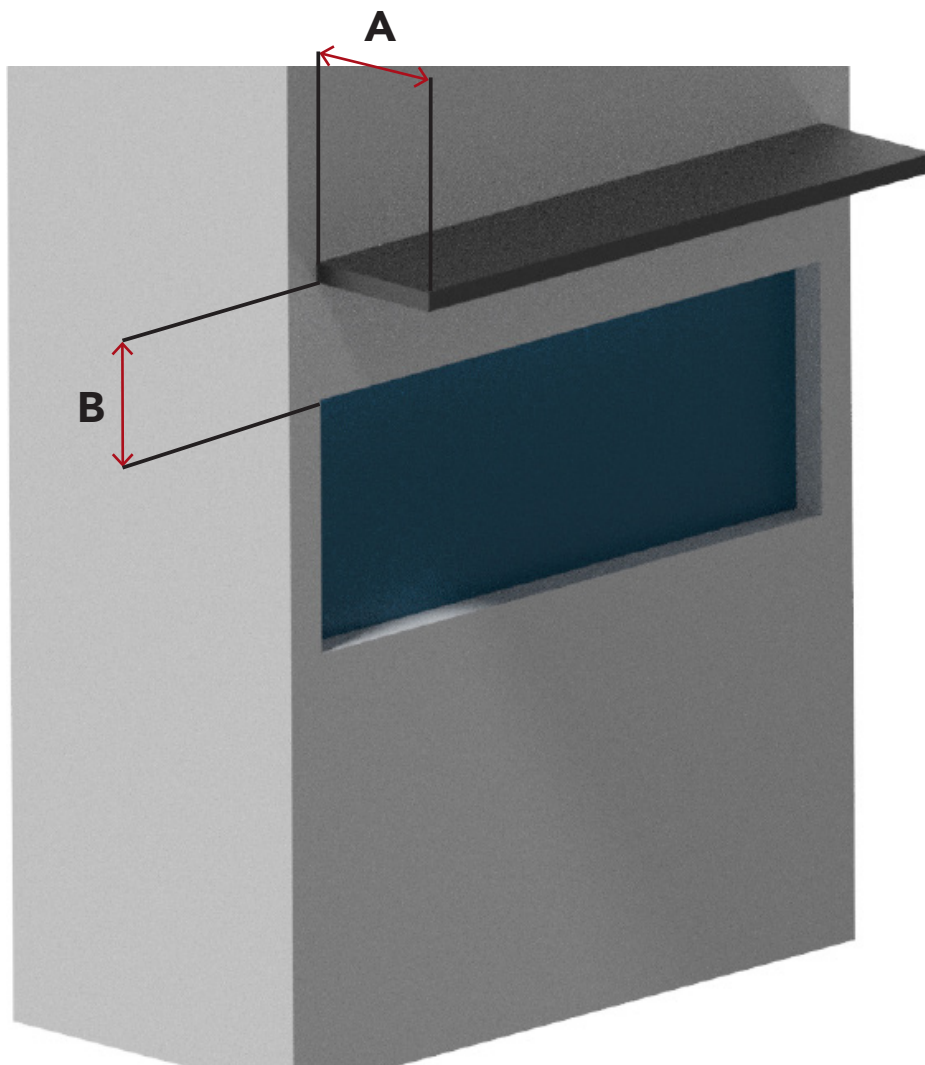

IF A	THEN B
50 mm	Min. 200 mm
100 mm	Min. 250 mm
150 mm	Min. 300 mm
200 mm	Min. 350 mm
250 mm	Min. 400 mm
300 mm	Min. 450 mm

DISTANCE FROM GLASS TO COMBUSTIBLE SIDE WALL

GB

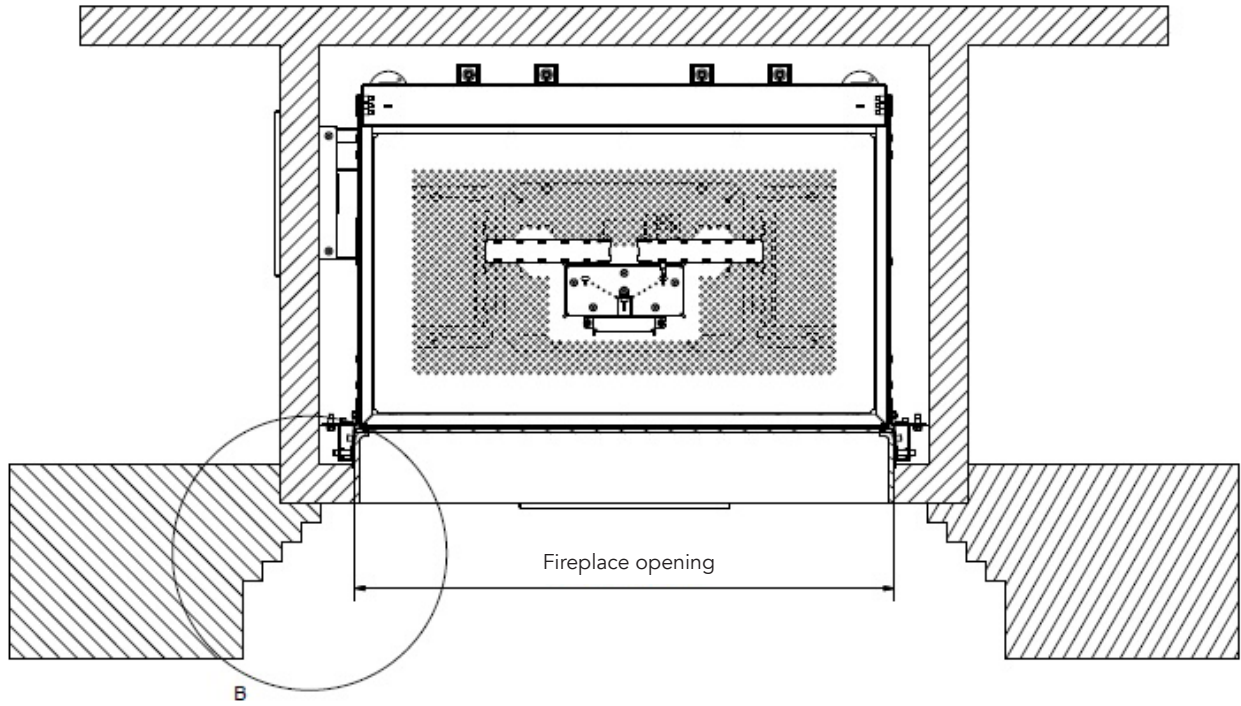

B

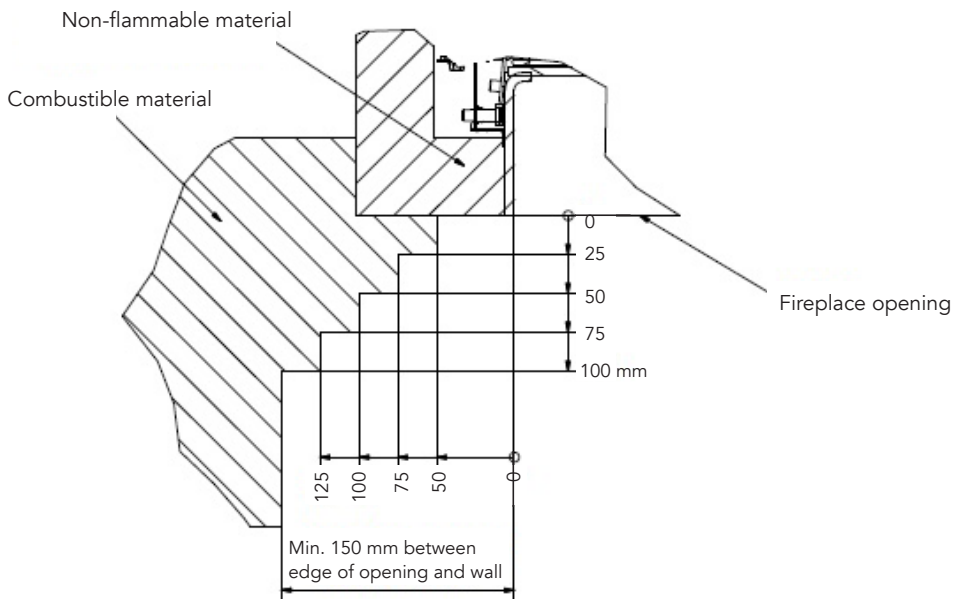

CONSTRUCTION EXAMPLE

The installation of Visio 90 RD and Visio 90 T must be fitted with convection openings which have a minimum area of 200 cm² above the fireplace and 200 cm² below the fireplace.

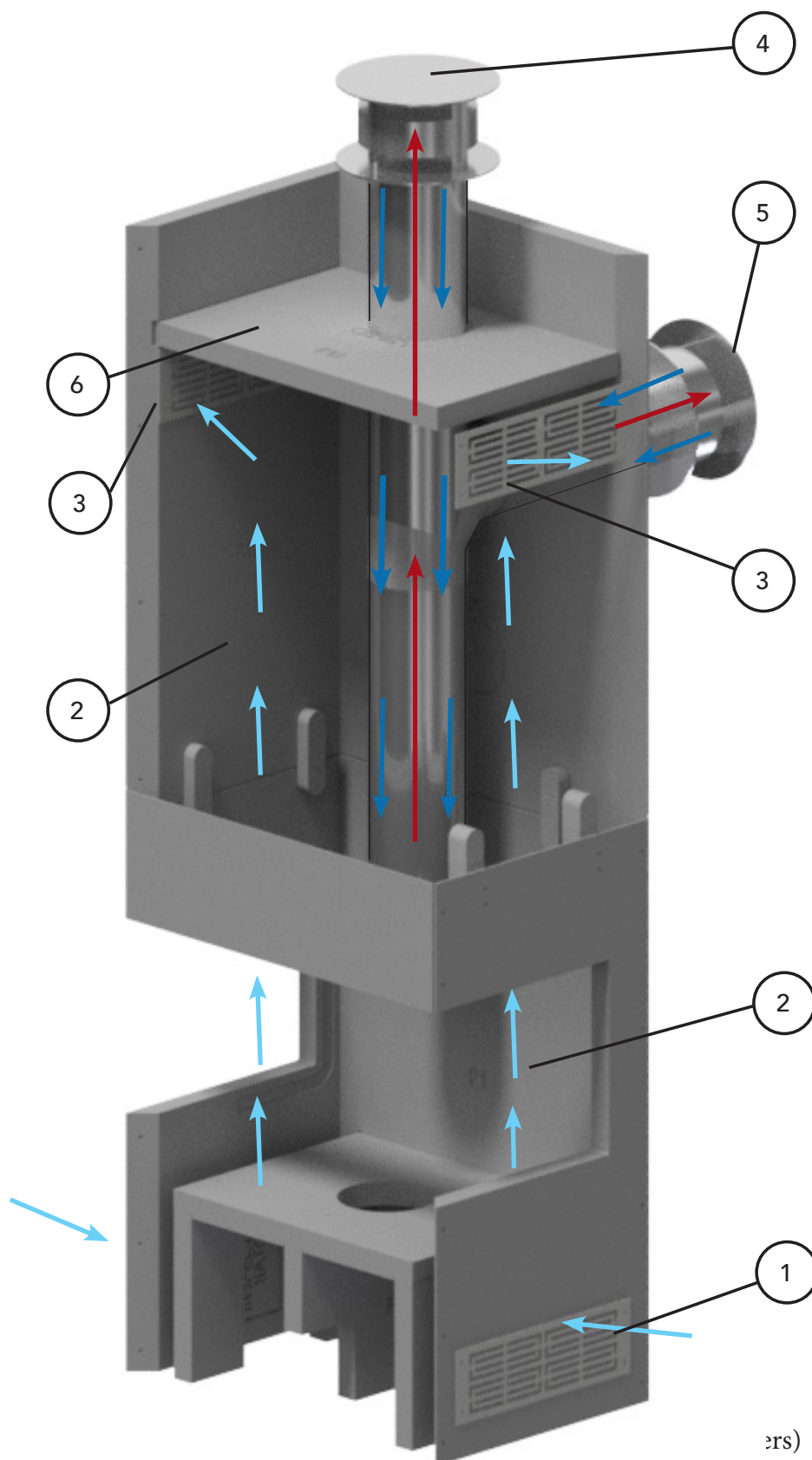

DEFINITION

1. Inlet convection
2. Natural convection
3. Outlet convection
4. Roof terminal
5. Wall terminal
6. Ceiling protection

ers)

FITTING THE FRAME (OPTIONAL)

When the ceramic logs and embers layer are correctly positioned in the gas fireplace, refit the glass as described in the section "Mounting the glass" on page 16.

PROCEDURE TO FIT THE FRAME:

1. Fit the frame in the top of the gas fireplace using the accompanying screws (see the arrows).
2. Place the bottom frame – the magnets ensure that the frame is secure.
3. Place the two side frames – the magnets ensure that the frames are secure.

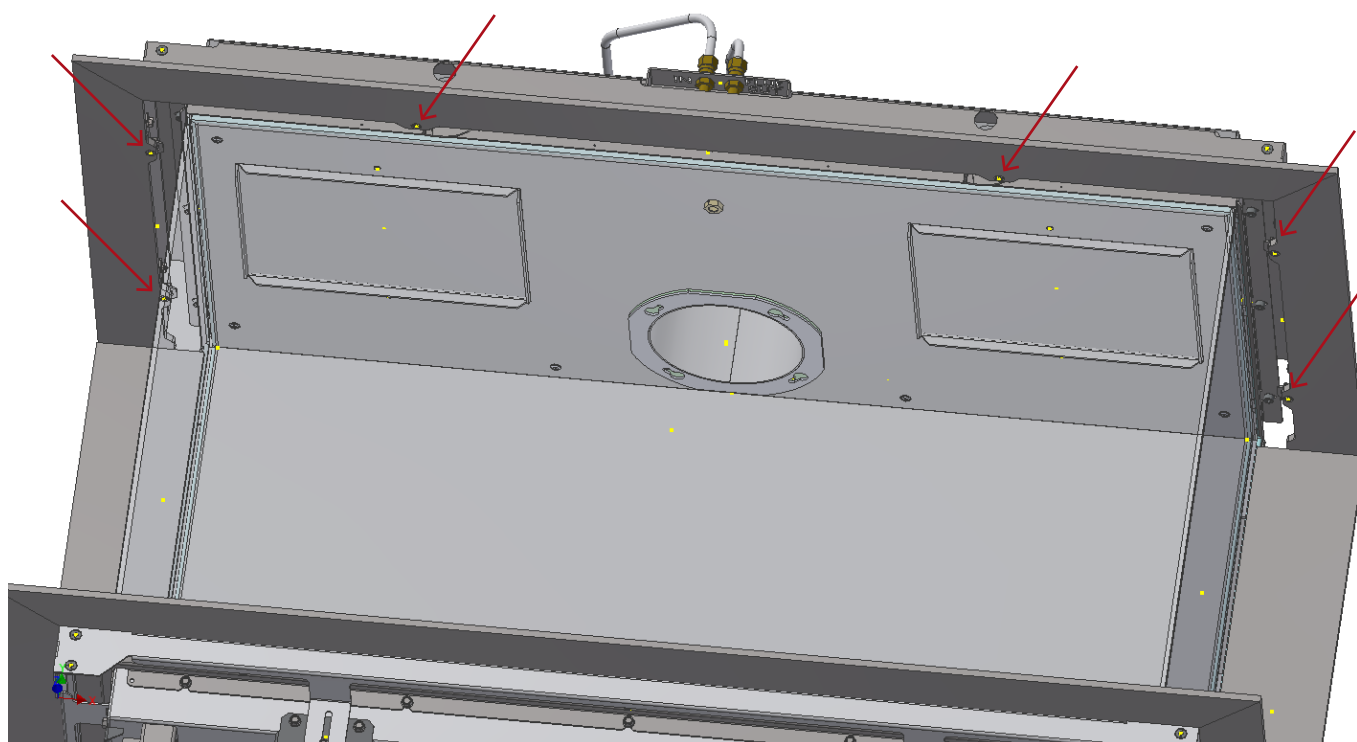

ADJUSTING THE BASE FRAME

If instead of the optional frame (6 mm), a thicker base frame is used, the height can be adjusted on the brackets.



STARTING THE GAS FIREPLACE

Before igniting the fire for the first time, ensure that all the packaging, labels, etc., are removed from the fireplace and the glass is cleaned.

Read more about cleaning the gas fireplace on page 48.

PROCEDURE

1. Check that the delayed ignition flap can be easily lifted inside the fireplace roof (see the photos below).
Make sure that the gaskets are placed correctly and are not damaged.
2. Ignite the gas fireplace and allow it to burn on high heat for a couple of hours.

See the separate user manual for a detailed guide on how to use the remote control.

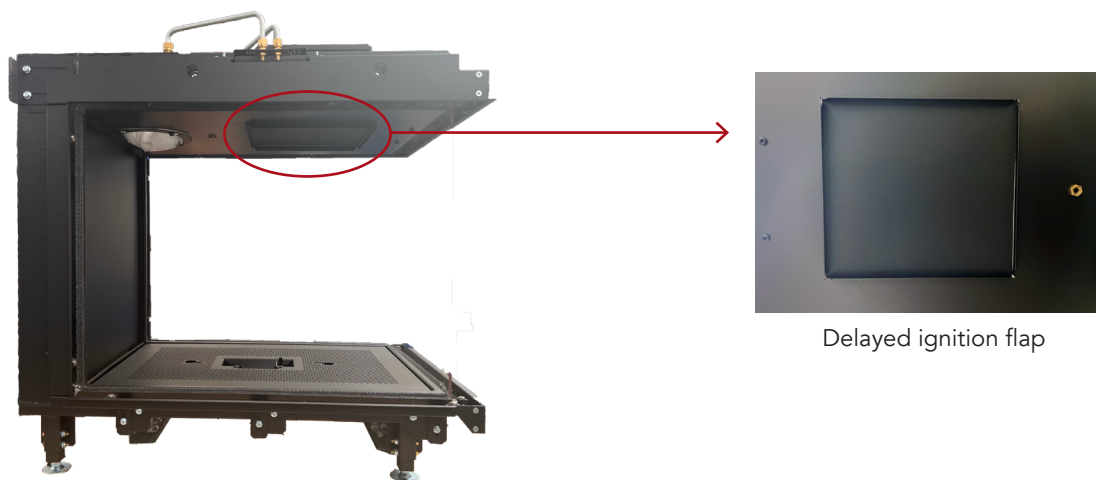

SOUNDS

The fireplace can emit a “clicking” sound when it is heating up and cooling down. This is due to the large temperature differences the material is exposed to.

DEW AND CONDENSATION

The fireplace can form dew on the fireplace glass at start-up. When the glass is cold and the appliance is lit, it may cause condensation and fog the glass. This condensation is normal and will disappear within 10-15 minutes as the glass and flue heats up.

Do not turn off the fireplace before all dew on the glass is gone!

If the fireplace is turned-off before the dew is gone, the water particles can damage the fireplace.

NOTE!

Ventilate the room when you ignite the fireplace for the very first time. The fireplace may emit a little smoke and a slight odour when it is lit for the first time.

Ensure that the room is well ventilated during this time. Children and pets should be kept away from the fireplace during this process. Please exercise caution during this process: do not touch visible surfaces/glass, as these will become very hot.

MANUAL EXTINGUISHING OF THE FIRE

To extinguish the gas fireplace manually (e.g. if you cannot find the remote control or the remote control has no batteries) shut off the gas supply and electrical supply.

If the fireplace has not been used for a longer period, follow the procedure for igniting the fire for the very first time.



PURGING THE GAS PIPE

When the gas supply is connected for the first time, the supply lines will be filled with air. The gas supply can then be purged by unscrewing the inlet pressure tap on the side of the burner.

PURGING THE GAS PIPE

Scan the QR code to watch a how-to-video



NOTE!

When the purging is complete, retighten the "pressure tap" screws. Check the system for gas leaks.

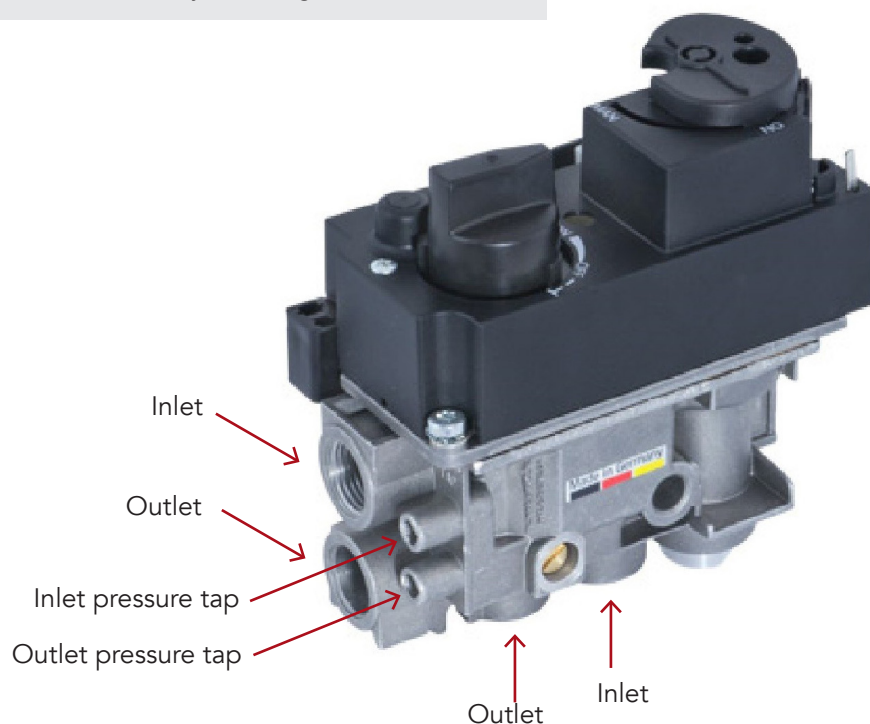

FUNCTIONAL TEST

Read these steps to check the function of the start-up of the gas fireplace.

1. Ignite the fireplace.
2. Check that the pilot flame ignites.
3. Check the pilot flame remains lit.
4. Check that the main burner ignites easily within 20 sec.
5. Check that the cross ignition from the pilot flame to the main burner occurs easily and that the main burner and pilot flame remain lit.
6. Check that the secondary burners remain lit.
7. Switch off the fireplace completely. The fireplace may only be ignited again after the thermocouple has cooled down. This will take about 1-2 minutes.

PRESSURE SETTING ADJUSTMENT

The fireplace should be pressure adjusted according to the data sheets from page 54. "Inlet pressure" (supply pressure to the GV60 Combination Valve) and "Burner pressure" (nozzle pressure) must ALWAYS be measured and, if necessary, corrected by an authorised installer.

BURNER PRESSURE

Scan the QR code to watch a how-to-video



GB

1. Loosen the screw to the "Outlet pressure tap" on the gas valve and connect a gas manometer.
2. Turn on the fireplace at maximum load – and let it burn for 45 minutes before measuring.
3. Check that the measured pressure agrees with the pressure stated on the information label.
4. The main burner pressure can be adjusted by removing the plug for the "pressure regulator".
5. Turn off the fireplace to minimum load.
6. The minimum burner pressure can be adjusted by the screw "minimum rate orifice".
7. After the pressure test is completed, retighten the "pressure tap" screws. Check the system for gas leaks.

The measured values must be within $\pm 10\%$ of the stated pressure. If this is not the case, contact the supplier.

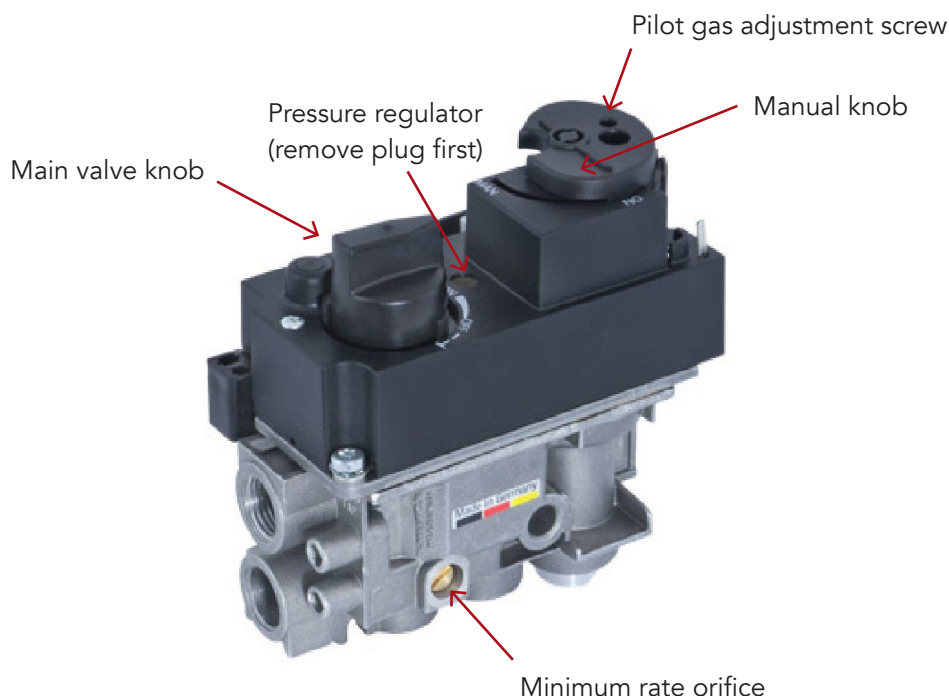

WARNING!

The pressure test and adjustment may only be performed by an authorised installer.

After the pressure test is completed and the gas manometer has been removed, re-tighten the "pressure tap" screws. Check the system for gas leaks.



CO AND O₂ MEASUREMENT

Our fireplaces are fitted with measuring points at the top of the glass. This gives easy access to measurements.

You will find the points here:

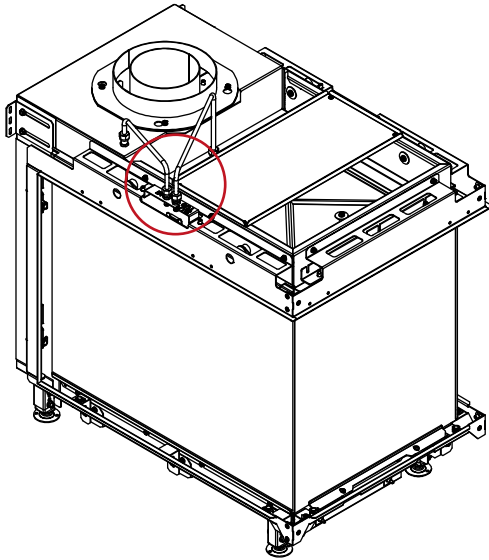

Room Divider

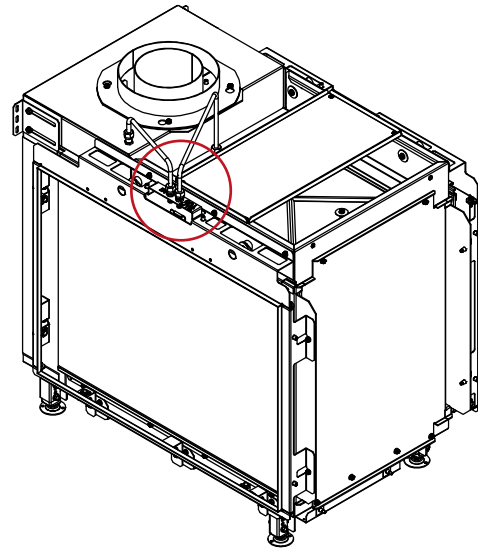

Tunnel

There are two points. The point at the rear/right end "IN" is for O₂ and the "FLUE OUT" is for CO measurements.

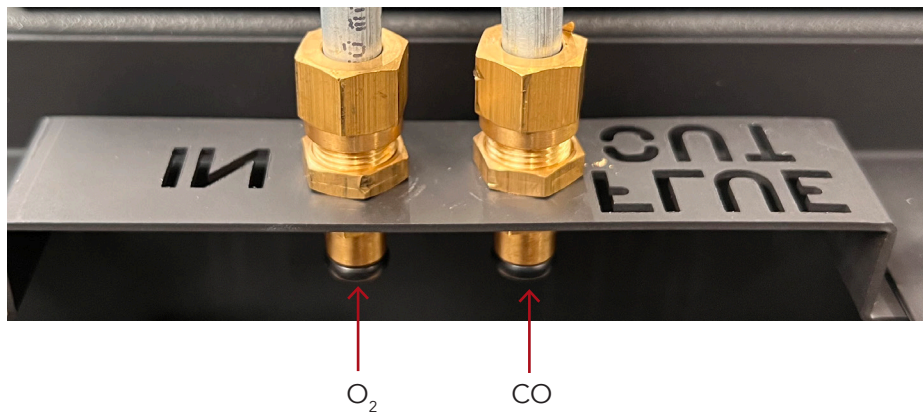

CO measurements are done when the fireplace has been running at full load for 45 minutes, The value must not exceed the level of national requirements. Wait 25 minutes between the measurements below.

CO levels must not exceed 1000 ppm. O₂ measurement in the outer pipe has to be minimum 19%.

CO measurement on maximum load

1. Put the fireplace in maximum load by pressing  twice quickly on the remote control.

CO measurement on minimum load

1. Push the  until the secondary burners are shut off.

2. Put the fireplace in minimum load by pressing  twice quickly on the remote control.

SERVICE AND MAINTENANCE

We recommend a yearly service check of the fireplace to ensure a long and lasting fireplace with a beautiful flame picture.

SERVICE PROCEDURE

The fireplace must be inspected by an authorised gas installer or other professional in accordance with national law. The inspection must ensure the product's operation and safety.

Switch off the fireplace and shut off the gas supply. Make sure the fireplace is completely cold before you begin. RAIS cannot be held liable for injuries that result from touching a hot fireplace.

The steps below can be used as a guideline.

RECOMMENDED SERVICE GUIDELINE

1. Protect the floor by laying out a blanket or other covering.
2. Turn off the gas supply and electrical supply.
3. Remove the glass and carefully remove the ceramic logs and embers layer.
4. Use a vacuum cleaner to clean the burner and the perforated plate.
5. Raise and remove the secondary burners. Remove the perforated plate.
6. Vacuum the entire burner.
7. If needed, soot on the logs can be removed by a soft brush.
Clean the pilot burner assembly using a soft brush and a vacuum cleaner. Do not bend or straighten the thermocouple. If the thermocouple is worn down, we recommend changing it during a service.
8. Check that the pilot burner gaskets (green) are in good condition. We recommend to always exchange the gaskets doing service.
9. Refit the perforated plate.
10. Check the flue gas system and the flue terminal and ensure that they are not blocked.
11. Put back the embers layer and ceramic logs. Follow the manual, the logs and ember should be placed in a very certain way – See the manual for placing the logs in the correct way.
Check that the gaskets for the glass are in good condition.
12. Clean and reinstall the glass.
13. Switch on the gas and electrical supply and check for leaks. Check the burners and pilot unit to ensure that they are in good working condition.
Ignite the fireplace and check the pressure setting.
14. Ensure that the fireplace is safe to use.
15. Worn out parts should be replaced with new original parts.
16. Be sure to dispose the replaced parts in the appropriate waste containers.

NOTE!

The fireplace must be inspected by an authorised gas installer or other professional in accordance with national law.



CLEANING

The fireplace should be cleaned of dust and foreign objects when you use it for the first time in the year, and especially if the fireplace has not been used for a longer period.

You could do this using a soft brush and a vacuum cleaner or by using a damp cloth with a non-abrasive cleaning agent. Never use corrosive or abrasive substances to clean this fireplace. The fireplace must be cold before you clean it.

If the glass has a layer of soot, clean the glass using a glass cleaner. Clean the outside of the fireplace using a dry cloth.

Before using the fireplace for the first time in the year, the flue system and flue gas connection must always be checked for blockages.

Check the outside and inside of the fireplace for any damage and pay particular attention to gaskets. Only original RAIS spare parts may be used.

CLEANING THE CERAMIC LOGS

1. Remove the ceramic logs as described in steps 1-3 in "Recommended Service Guideline" on page 47.
2. Carefully clean the ceramic logs using a soft brush and a vacuum cleaner. Damaged parts may only be replaced by original RAIS specified parts.
3. The scrapped ceramic parts should be disposed of in the correct municipal disposal centres. It is recommended that you use a vacuum cleaner with a HEPA filter system.
4. Put back the embers layer and fit the glass. Ensure that the fireplace functions correctly and is safe to use.



NOTE!

Non-reflecting glass must never be cleaned using special glass cleaner – only use water.
Only clean the glass when the fireplace is cold.

WARRANTY

RAIS offers a 2-year warranty on all gas fireplaces. The warranty period begins upon delivery of the product.

The warranty – provided by RAIS – is a supplement to national guarantee requirements applicable in the country where the fireplace was purchased.

GENERAL

- Renewal or replacement of components does not extend the warranty period.
- The warranty is only valid if the gas fireplace is sold through an official RAIS dealer.

MAINTENANCE OF YOUR GAS FIREPLACE

We recommend having your gas fireplace inspected by a professional once a year to ensure the product's operation and safety. Read more on page 47.

THE WARRANTY COVERS:

- Documented malfunctions due to faulty workmanship.
- Documented faulty material.
- The gas fireplace cabinet, which is backed by a 5-year warranty.

THE WARRANTY DOES NOT COVER:

- Stainless steel surfaces' appearance, colour changes and patina.
- Thermal expansion noises.

THE WARRANTY BECOMES VOID:

- If installation or repair does not comply with national or local law.
- In the event of damage due to external influences and the use of unsuitable fuels.
- If the gas fireplace has not been installed according to the installation instructions or used according to the user manual.
- In case of failure to comply with statutory or recommended installation regulations and in the event of any owner-made changes to the fireplace.
- In case of lacking maintenance (see the section in the Installation Manual regarding Service and Maintenance).
- When using non-original components that do not have the same specifications as the original.
- In case of damage caused by external factors (such as shock, lightning, impact, flooding or overheating of the fireplace) during transport, storage or installation.
- In case of defects owing to neglect, misuse and/or gross negligence.

IN CASE OF DAMAGE, CONTACT YOUR DEALER

In the event of damage to your gas fireplace, please contact the retailer where the product was purchased and provide the serial number.

In the event of a warranty claim, RAIS determines the way in which the damage will be repaired. In the event of repair, we will ensure professional execution.

For warranty claims on parts that have been replaced or repaired, please refer to national/EU laws and regulations on renewed warranty periods.

The warranty provisions in effect at any time may be obtained from RAIS.

TROUBLESHOOTING

If you, against all expectation, should experience issues with your fireplace, please try the following steps. If the issues persist, please contact your RAIS dealer and state in which step the problem occurred.

The most seen problem is lost connection between remote control and receiver due to lack of power. Therefore, we recommend changing the batteries in your remote and resetting the connection between the receiver and remote. Please follow the guide on page 33.

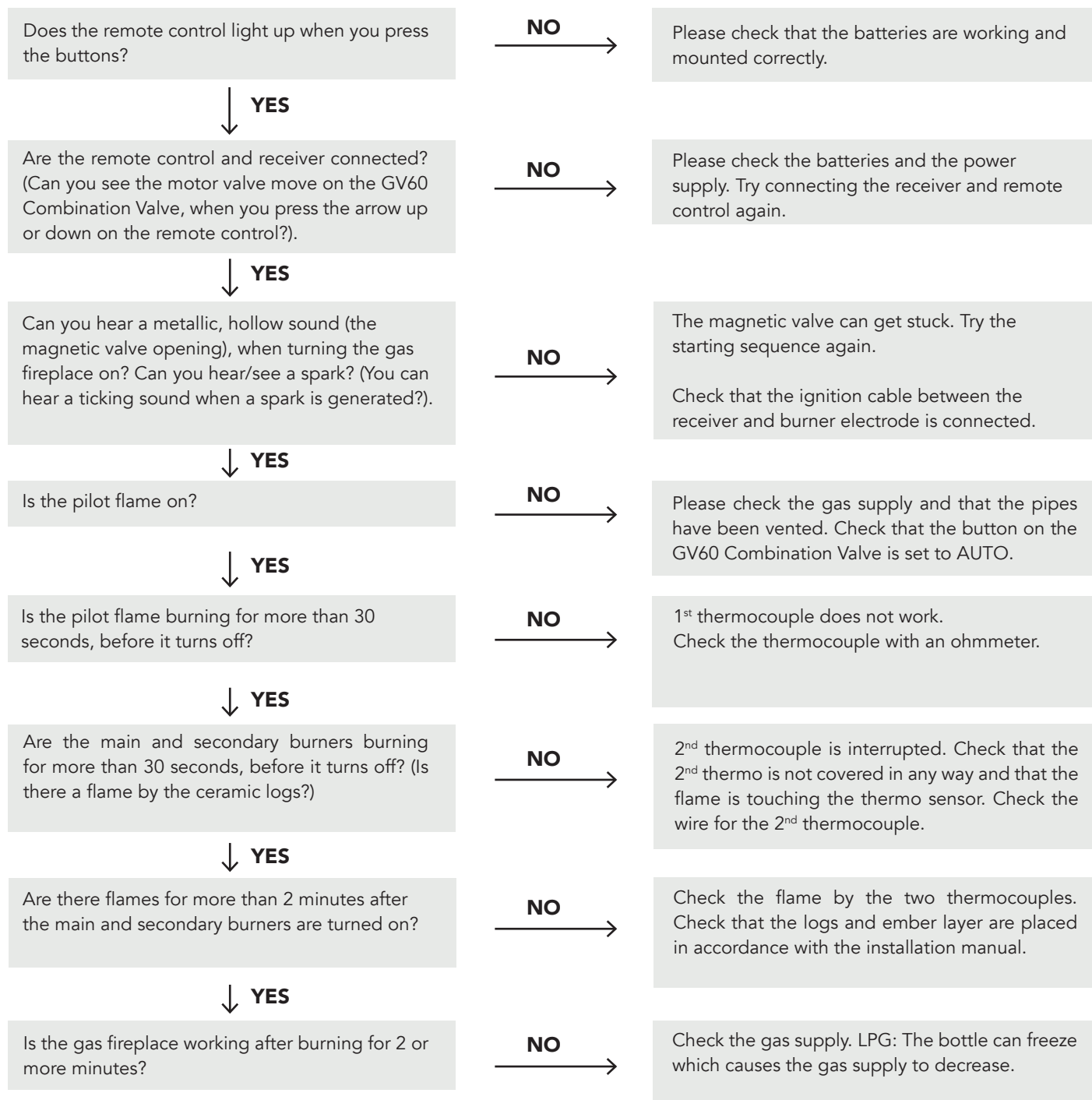

ERROR CODES ON THE REMOTE CONTROL

ERROR CODE	SYMPTOM	POSSIBLE CAUSE
F04	<ul style="list-style-type: none"> No pilot within 30 sec. Note: After 3 failed ignition sequences F06 is shown. 	<ul style="list-style-type: none"> No gas supply Air in pilot supply line No spark Reversed polarity in 1st thermocouple wiring
F06	<ul style="list-style-type: none"> 3 failed ignition sequences within 5 minutes Fire is not responding, no pilot flame 	<ul style="list-style-type: none"> No gas supply Air in pilot supply line No spark Reversed polarity in 1st thermocouple wiring Incorrect pilot orifice if valve has been converted from LPG to NG or vice versa.
F09	<ul style="list-style-type: none"> Fire is not responding No electric control of the fire 	<ul style="list-style-type: none"> The down arrow button was not pushed during pairing. Receiver and handset are not synced
F40	<ul style="list-style-type: none"> Battery icon flashes on handset display 	<ul style="list-style-type: none"> Low battery in handset
F46	<ul style="list-style-type: none"> Fire is not responding Intermittent response No electronic control of the fire 	<ul style="list-style-type: none"> No or bad connection between the receiver and handset No power to the receiver Low communication range (Main adapter faulty, handset not communicating with the receiver)

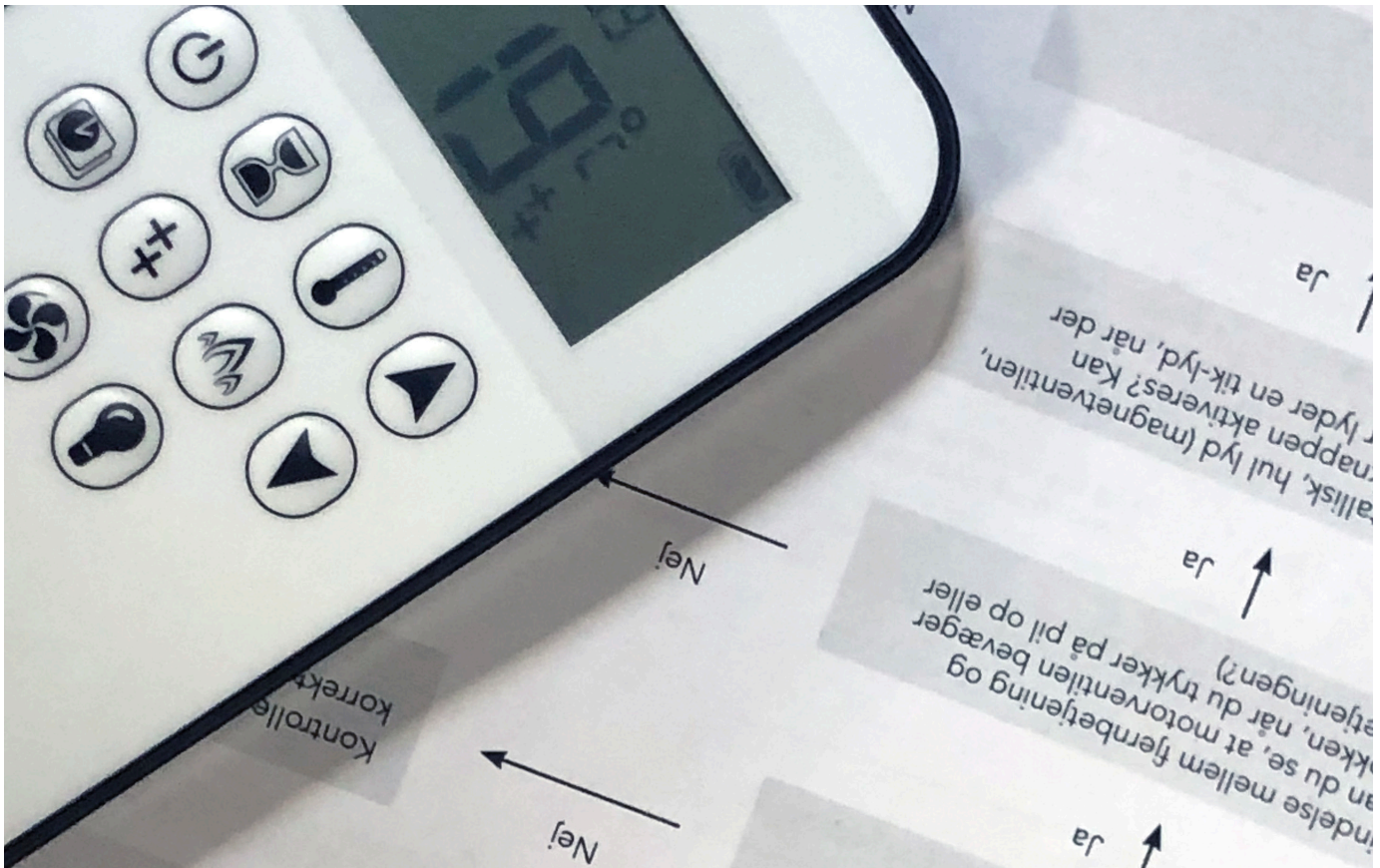

ERROR CODES ON THE APP

ERROR CODE	MESSAGE SHOWN IN APP	SYMPTOM	POSSIBLE CAUSE
F02	F02 Contact Service	<ul style="list-style-type: none"> 5 sec. beep from the receiver Fire is not responding, no ignition 	<ul style="list-style-type: none"> Microswitch not making contact with the cam on the motor knob Motor wiring incorrect Reversed polarity or faulty microswitch Bent motor knob
F03	F03 Contact Service	<ul style="list-style-type: none"> 5 sec. beep from the receiver Ignition process is interrupted Fire is not responding, no ignition 	<ul style="list-style-type: none"> Thermocouple wiring incorrect or interrupted ON/OFF switch in "O" (OFF) position
F04	F04 Ignition Sequence malfunction Wait 1 minute Retry ignition	<ul style="list-style-type: none"> No pilot flame within 30 sec. NOTE: After 3 failed ignition sequences F06 shown 	<ul style="list-style-type: none"> No gas supply Air in pilot supply line No spark Reversed polarity in thermocouple wiring Incorrect pilot orifice if valve has been converted from LPG to NG or vice versa
F06	F06 Contact Service	<ul style="list-style-type: none"> 3 failed ignition sequences within 5 minutes Fire is not responding, no pilot flame 	<ul style="list-style-type: none"> No gas supply Air in pilot supply line No spark Reversed polarity in thermocouple wiring Incorrect pilot orifice if vave has been converted from LPG to NG or vice versa
F10	F10 Contact Service	<ul style="list-style-type: none"> Pilot lit Main burner fails to ignite and pilot shuts off Ignition is blocked for 2 minutes 	<ul style="list-style-type: none"> 2nd thermocouple is out of position 2nd thermocouple wiring incorrect Gas logs out of position Gas ports for burner are blocked
F12	F12 Contact Service	<ul style="list-style-type: none"> Motor turns to pilot position Fan at level 4 for 10 minutes 	<ul style="list-style-type: none"> Receiver temperature exceeds 60°C Receiver powered by batteries Blocked flue, no air circulation in firebox Heat shield incorrectly installed
F13	F13 Contact Service	<ul style="list-style-type: none"> Motor turns to pilot position 	<ul style="list-style-type: none"> Receiver temperature exceeds 80°C
F14	F14 Contact Service	<ul style="list-style-type: none"> 5 sec. beep from the receiver Fire is not responding, no ignition 	<ul style="list-style-type: none"> Receiver software doesn't support on 2nd thermocouple Wrong receiver
F15	F15 Contact Service	<ul style="list-style-type: none"> 5 sec. beep from the receiver Fire is not responding, no ignition 	<ul style="list-style-type: none"> 2nd thermocouple is not connected 2nd thermocouple wiring
F16	F16 Contact Service	<ul style="list-style-type: none"> No temperature shown in the app 	<ul style="list-style-type: none"> Handset out of range for more than 1.5 h Electrical interference
F17	F17 Contact Service	<ul style="list-style-type: none"> No ignition (fire is not responding) 	<ul style="list-style-type: none"> Inlet voltage exceeds 7.25 V Malfuction of the main adapter
F19	F19 Contact Service	<ul style="list-style-type: none"> Pilot drops when moter opens main gas 	<ul style="list-style-type: none"> Insufficient thermo-voltage Thermocouple malfunction Low inlet gas pressure Improper thermocouple flame impingement Carbon build-up on the thermocouple Valve malfunction Resistance in thermocurrent circuit
F26	F26 Contact Service	<ul style="list-style-type: none"> It is not possible to increase flame height after ignition Fan at level 4 for 10 minutes (T>60°C) 	<ul style="list-style-type: none"> Receiver temperature exceeds 60°C
F28	F28 On-Demand Pilot	<ul style="list-style-type: none"> Pilot shuts off after a predefined time 	<ul style="list-style-type: none"> Pilot shuts off after no motor movement for a predetermined time
F31	F31 Contact Service	<ul style="list-style-type: none"> Fire is not responding No electronic control of the fire 	<ul style="list-style-type: none"> Receiver malfunction
F41	F41 Check WiFi	<ul style="list-style-type: none"> Fire is not responding No electronic control of the fire 	<ul style="list-style-type: none"> No power to WiFi module or router No WiFi connection between WiFi module and router, and/or smart device
F43	F43 No receiver connected Contact Service	<ul style="list-style-type: none"> Fire is not responding No electronic control of the fire 	<ul style="list-style-type: none"> No communication between receiver and WiFi module
F44	F44 Contact Service	<ul style="list-style-type: none"> No temperature shown in the app "N.a." (not applicable) displayed in the app 	<ul style="list-style-type: none"> Handset not within range Low battery in handset

INFORMATION LABEL

This gas fireplace is tested and certified for use in several countries. The gas fireplace has been tested for use with natural gas, LPG and biogas.

18		2575-24		0359-24	C11 C31 C91			
Produkt ID/ Product ID/ ID du produit/ Produziert von: 2575DM29341								
Produceret af/Produced at/Produit par/Produziert von - RAIS A/S, Industrivej 20, 9900 Frederikshavn, Denmark								
<input type="checkbox"/> Visio Gas 70 RD <input type="checkbox"/> Visio Gas 70 T		<input type="checkbox"/> Visio Gas 90 RD <input type="checkbox"/> Visio Gas 90 T		<input type="checkbox"/> Visio 100 RD <input type="checkbox"/> Visio 100 T				
(VISIO 6, 7 & 9)								
- Dette apparat skal installeres i overensstemmelse med gældende regler og kun bruges i et tilstrækkeligt ventileret rum. Konsulter instruktionerne før installation og brug af dette apparat. Testet og certificeret til brug med biopropan. Effektivitetsklasse 1. -This appliance must be installed in accordance with the rules in force, and only used in a sufficiently ventilated space. Consult instructions before installation and use of this appliance. Tested and Certified for use on Biopropane. Efficiency class 1. -Cet appareil doit être installé conformément aux règles en vigueur et utilisé uniquement dans un espace suffisamment ventilé. Consultez les instructions avant l'installation et l'utilisation de cet appareil. Testé et certifié pour l'utilisation avec du biopropane. Classe d'efficacité 1. -Dieses Gerät muss gemäß den geltenden Vorschriften installiert werden und darf nur in einem ausreichend belüfteten Raum verwendet werden. Bitte konsultieren Sie die Anweisungen vor der Installation und Verwendung dieses Geräts. Getestet und zertifiziert für die Verwendung mit Biopropan. Energieeffizienzklasse 1.								
Seriennummer/Serial number/Numéro de série/Seriennummer			Brænder ID/Burner ID/ID du Brûleur/ Brenner ID					
Gas kategori og forsyningstryk		Indgang	Udgang	Min. Udgang	Brænder tryk høj (Varm)	Brænder tryk lav (Varm)	Destinationsland	
Gas category and supply pressure		Input	Output	Min. Output	Burner pressure high (Hot)	Burner pressure low (Hot)	Country of destination	
Catégorie de gaz et pression d'alimentation		Entrée	Sortie	Sortie min	Pression du brûleur élevée (Chaud)	Pression du brûleur basse (Chaud)	Pays	
Gas Kategorie und Versorgungsdruck		Eingang	Ausgang	Min. Leistung	Brennerdruck hoch (Warm)	Brennerdruck-niedrig (Warm)	Zielland	
		(Hi, kW)	(Hi, kW)	(Indicative kW)				
N G	<input type="checkbox"/> I2H/ I2E	G20 20 mbar	9,5	8,5	1,1	18,5 Interval 16,7 - 20,4	8 Interval 7,2 - 8,7	AT, CH, CZ, DE, DK, EE, ES, FI, GB, GR, HR, IE, IT, LT, LU, LV, NO, PL, PT, RO, SE, SI, SK, TR
	<input type="checkbox"/> I2ELL	G25 20 mbar	8,1	7,4	1,1	18 16,2 - 19,8	7,8 7 - 8,5	DE
	<input type="checkbox"/> I2E+	G20 20 mbar	9,5	8,5	1,1	18,5 16,7 - 20,4	8 7,2 - 8,7	BE, FR
	<input type="checkbox"/> I2E+	G25 25 mbar	8,8	8,0	1,1	22 19,8 - 24,2	8,5 7,7 - 9,3	BE, FR
	<input type="checkbox"/> I2L / I2EK / I2 (43.46-45.3 MJ/ m3 Oc)	G25.3 25 mbar	8,9	8,1	1,1	22,2 20 - 24,4	8,5 7,7 - 9,3	NL
TOWN GAS	<input type="checkbox"/> G150.1 8 mbar	6,4	4,8	1,0	5 4,5 - 5,5	2,1 1,9 - 2,3	DK, SE	
	<input type="checkbox"/> G150.1 10 mbar	7,4	5,7	1,0	6 5,4 - 6,5	2,6 2,3 - 2,9	DK, SE	
L P G	<input type="checkbox"/> I3+ (28-30/37)	G30 30 mbar	11,7	9,4	1,1	27,2 24,5 - 29,9	12 10,8 - 13,1	BE, CH, CY, CZ, ES, FR, GB, GR, IE, IT, PT, SI, SK, TR
	<input type="checkbox"/> I3+ (28-30/37)	G31 37 mbar	11,2	8,9	1,8	27,2 24,5 - 29,9	12 10,8 - 13,1	BE, CH, CY, CZ, ES, FR, GB, GR, IE, IT, PT, SI, SK, TR
	<input type="checkbox"/> I3P (30)	G31 30 mbar	9,9	7,9	1,0	27,5 24,8 - 30	12 10,8 - 13,1	FI, NL, RO
	<input type="checkbox"/> I3P (37)	G31 37 mbar	11,2	8,9	1,8	27,2 24,5 - 29,9	12 10,8 - 13,1	BE, CH, CZ, ES, FR, GB, GR, HR, IE, IT, LT, NL, PL, PT, SL, SK, TR
	<input type="checkbox"/> I3P (50)	G31 50 mbar	11,2	8,9	1,8	27,2 24,5 - 29,9	12 10,8 - 13,1	AT, CH, CZ, DE, NL, SK
	<input type="checkbox"/> I3B/P (30)	G30 30 mbar	11,7	9,4	1,1	27,2 24,5 - 29,9	12 10,8 - 13,1	BE, BG, CY, DK, EE, FI, FR, GB, GR, HR, HU, IT, LT, MT, NL, NO, RO, SE, SI, SK, TR
	<input type="checkbox"/> I3B/P (30)	G31 30 mbar	9,9	7,9	1,0	27,5 24,8 - 30	12 10,8 - 13,1	BE, BG, CY, DK, EE, FI, FR, GB, GR, HR, HU, IT, LT, MT, NL, NO, RO, SE, SI, SK, TR
	<input type="checkbox"/> I3B/P (50)	G30/G31 50 mbar	11,2	8,9	1,8	27,2 24,5 - 29,9	12 10,8 - 13,1	AT, CH, CZ, DE, FR, SK

SVGW Nr. 19-015-3

ATTIKA FEUER AG, Brunnmatt 16, CH-6330 Cham / RAIS A/S, Industrivej 20, DK-9900 Frederikshavn

TECHNICAL DATA SHEET – NATURAL GAS

Visio 90 RD and Visio 90 T (Visio 7)

GB

VISIO 7		NATURAL GAS											
Producer		RAIS											
Model		Visio Gas 90 RD Visio Gas 90 T											
Country code		AT, CH, CZ, DE, DK, EE, ES, FI, GB, GR, HR, IE, IT, LT, LU, LV, NO, PL, PT, RO, SE, SI, SK, TR											
Gas category		I2H/I2E											
Inlet gas pressure		G20@20		Interval		I2ELL		G25@20		Interval		I2L/I2EK/I2	
Nominal input		20,0				20,0		20,0		25,0		25,0	
Nett rate / calorific value (Hi)		8,1				6,5		8,1		7,3		7,4	
Max. Output		6,5				5,3		6,5		5,9		6,0	
Min. Output		1,1				1,1		1,1		1,1		1,1	
Volumetric flow rate		0,9				0,9		0,9		0,9		0,9	
Burner pressure high (hot)*		12,5		11,3 13,8		12,5		11,3 13,8		12,5		11,3 13,8	
Burner pressure min. (hot)**		19,5		17,6 21,5		13,3		12,0 14,6		19,5		17,6 21,5	
Concentric approvals		C11 / C31 / C91											
Exodraft Balanced Fan		Approved											
Concentric connection		Ø130 mm - Ø200 mm											
Type of burner		3243514											
Batteries for remote control		2x 1.5V AAA											
Electrical connection with LED (connection to LED box)		230 VAC / 50 Hz 12 V adapter											
Gas connection		To GV60 - 3/8" G / Ø12 mm To Flex hose - 1/2" G / Ø8 mm											
Injector marking		120 Center, 320 Left, 320 Right											
Air		Main venturi: Air ½ open Secondary venturis: One closed side / One hole side											
Pilot marking		G30-ZP2-312-31.1											
Efficiency class		1											
Nox class		5											

* Double burner's maximum - The appliance is switched on. Been burning for 45 minutes.

** Single burner - The appliance is switched on. Been burning for 45 minutes.

VISIO 90 RD

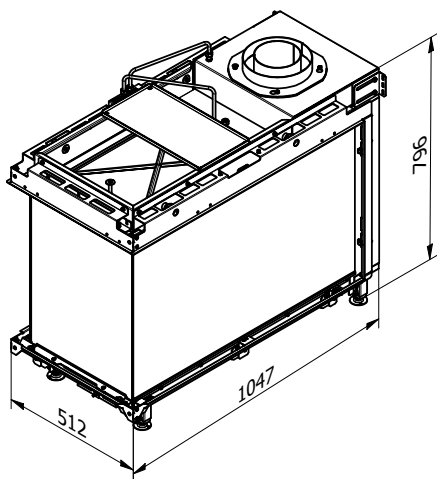
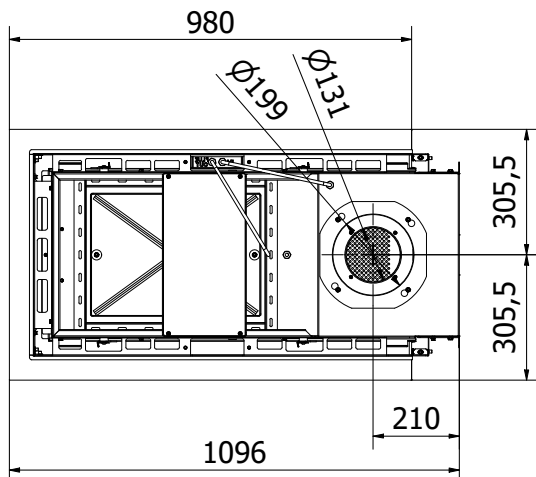
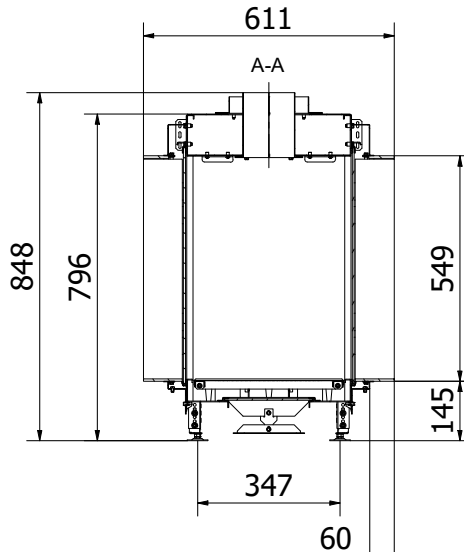
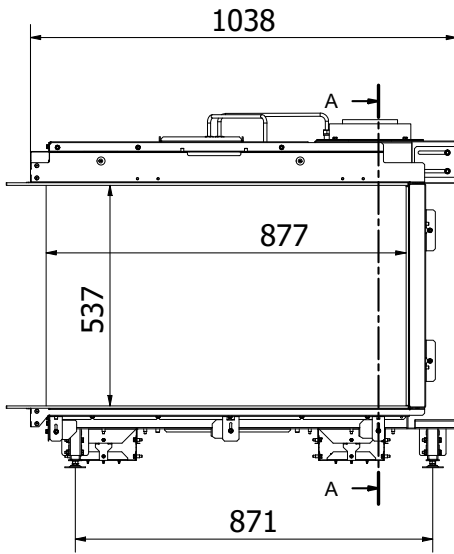

Without frame

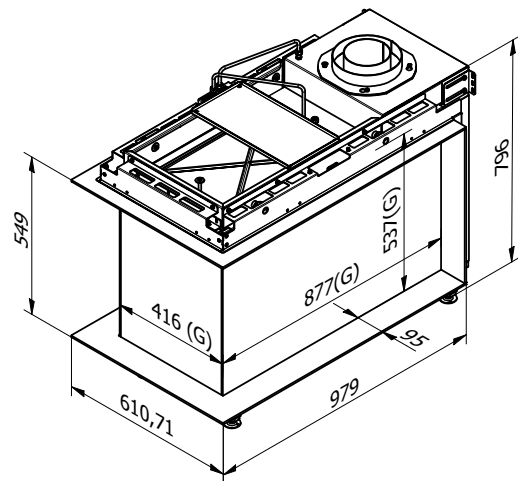

With frame

GB

VISIO 90 T

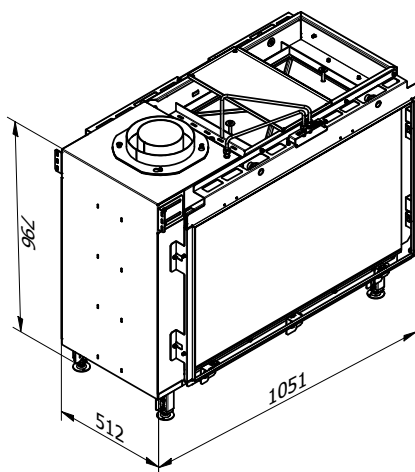
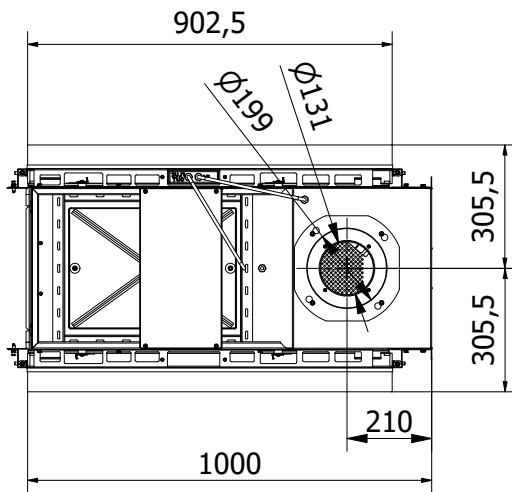
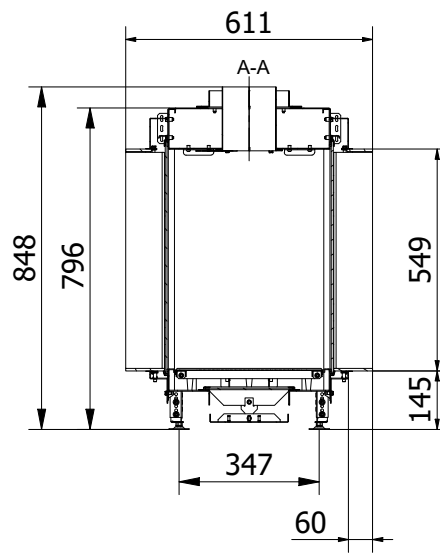
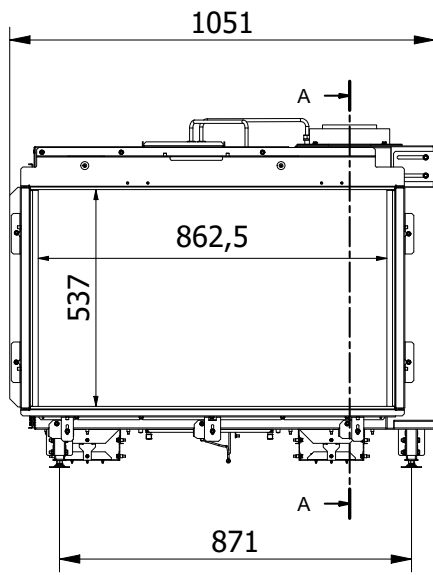

Without frame

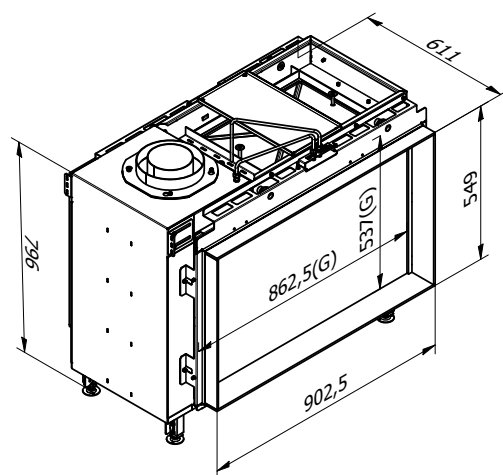

With frame



RAIS[®]

RAIS A/S
Industrivej 20
DK-9900 Frederikshavn
Denmark
www.rais.com

