



R600RD
R600T

INSTALLATION MANUAL (ENGLISH)

RAIS[®]

attika[®]
FEUERKULTUR

PRODUCTION NUMBER

The production number can be found on the frame under the door and at one of the front pages of the user manual.

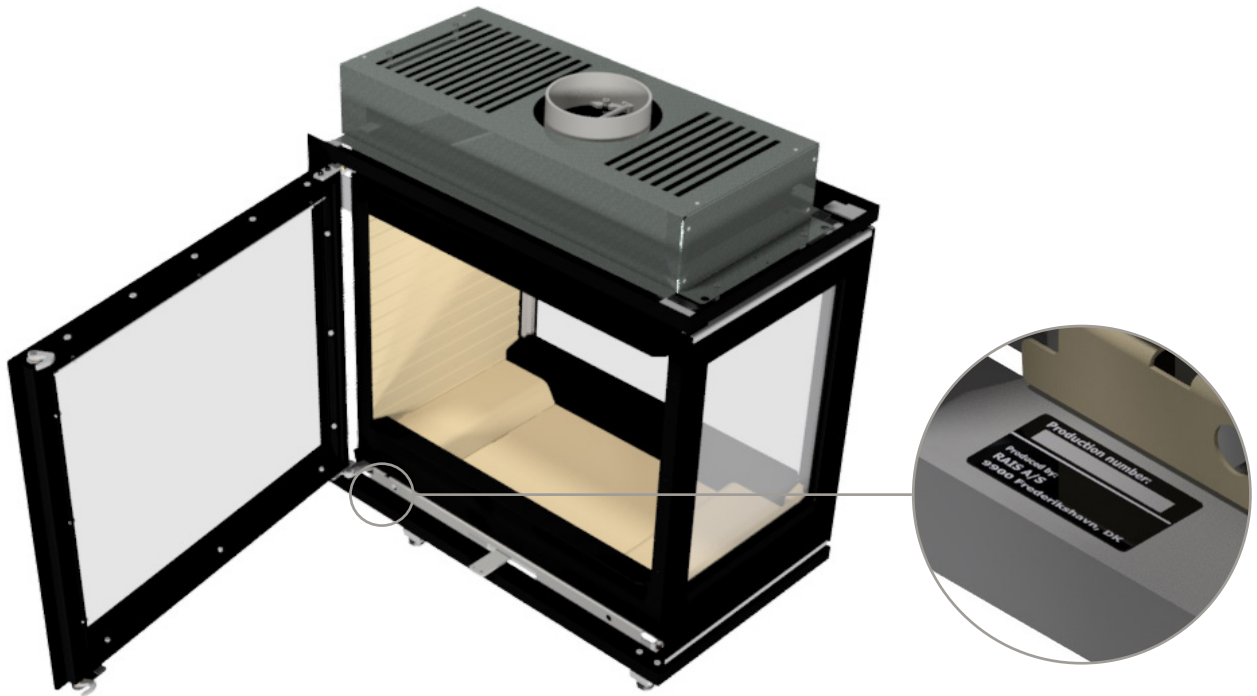

THIS MANUAL APPLIES TO THE FOLLOWING MODELS:

- R600RD
- R600T

R600RD



R600T



CONTENT

PRODUCTION NUMBER	2
INSTALLATION MANUAL	4
Malfunctions	5
TECHNICAL DATA	6
Specifications	6
INSTALLATION DISTANCE	8
DIMENSIONAL SKETCHES	9
INSTALLATION	11
Recycling of packaging	11
Packaging at delivery	12
Height adjustment	12
Removing the combustion chamber lining	13
Cleaning and maintenance	13
INSTALLATION DIMENSIONS	14
Installation dimensions R600RD	14
Installation dimensions R600T	15
Un-insulated flue	16
Insulated flue	16
EXTERNAL AIR CONNECTION - AIRSYSTEM	18
DISMOUNTING FRAMES	20
SPECIAL PRECAUTIONS FOR INSTALLATION IN UK	22

Revision: 1
Date: 27-02-2026

We reserve the right to make printing errors.

INSTALLATION GUIDE

Thank you for choosing your new RAIS or ATTIKA product! This installation instructions manual will ensure that your fireplace insert is installed correctly and that it will provide you with comfort and pleasure for many years to come.

GENERAL

It is important to correctly install the fireplace insert out of consideration for both the environment and personal safety. The installation must comply with all local rules and regulations, including those that refer to national and European standards. A certified chimney sweeper should be contacted before set-up. No unauthorised alterations may be made to the fireplace insert.

Upon receipt, inspect the stove for any transport damage. Do not install the stove until you have checked it thoroughly.

FLOOR CONSTRUCTION

The floor structure must be able to support the weight of the fireplace insert and a chimney, if required. If the existing floor structure does not meet this requirement, suitable measures must be taken (e.g. installation of a load distribution plate). If in doubt, contact a building expert.

National and local regulations must be complied with, including the size of the non-flammable plate that must cover the flammable floor in front of the fireplace insert to protect the floor from falling embers.

DISTANCE TO COMBUSTIBLE MATERIAL

The fireplace insert must be positioned at a safe distance from flammable material. Due to risk of fire, flammable items (e.g. furniture) may not be positioned closer to the insert than specified in the sections on placement. When deciding where to install your RAIS/ATTIKA fireplace insert, you should consider being able to heat other rooms in your home to get the most out of your new fireplace insert.

VENTILATING SYSTEMS

The stove needs permanent and sufficient air to operate safely and efficiently. A permanent air supply can be installed in the room for the stove's combustion air - through the AirSystem connection. Under no circumstances should this air supply be closed during operation. Note that any mechanical extraction such as a cooker hood can reduce the air supply. The stove has an air consumption of min. 17.6 m³/h.

CHIMNEY

As a minimum, the chimney must be constructed of T400-N1-D-50050-G100 flue pipe, and be tall enough that the draft conditions are in order, i.e. 12 pascal to 18 pascal. If the recommended chimney draught cannot be achieved, problems of smoke puffing from the door may arise when heating. The collar is 150 mm in diameter. Remember: there must be unobstructed access to the access door on the chimney.

If the draught is too strong, it is advisable to equip the chimney with a regulating damper. If a regulating damper is fitted, you must ensure that there is a free flow-through area of at least 20 cm² when the regulating damper is closed.

The length of the chimney, calculated from the top of the fireplace insert should not be less than 3 metres and must be at least 80 cm above the roof ridge. If the chimney is placed on the side of the house, the top of the chimney must never be lower than the roof ridge or the roof's highest point. Note that there are often national and local regulations relating to houses with thatched roofs.

Always make sure to comply with applicable standards (EN 15287-1:2023 and EN 15287-2:2023) for chimney installation. It is also important to check the correct functioning of the chimney according to EN 13384-2:2015+A1:2019 based on the individual solution on site

**ATTENTION!**

The appliance shall not be installed with ventilating systems which have pressure below -15 Pa.

ATTENTION!

Before the fireplace insert may be put to use, the set-up must be reported to your local chimney sweeper.



ATTENTION!

RAIS/ATTIKA recommends having the insert installed by an authorised technician. Please ask your dealer for further information.



MALFUNCTIONS

If you are experiencing disturbances, some of the most common causes are listed below.

SMOKE SPILLAGE AROUND THE DOOR

- This may be due to insufficient draft in the chimney <math><12\text{Pa}</math>
- Check whether the flue or chimney is blocked
- Check whether the hood is switched on and, if so, switch it off and open a window / door near the stove for a short period.

SOOT ON GLASS

- Excessively wet firewood
- The damper regulation is too low
- Ensure proper heating of the stove when lighting, prior to closing the door

STOVE IS BURNING TOO STRONG

- Leak around the door seal
- Chimney draft too large >18 Pa, draft regulator should be installed.
- The damper is not regulated down enough

STOVE IS BURNING TOO WEAK

- Insufficient wood
- Insufficient air supply for room ventilation
- Unclean smoke flue
- Leaky chimney
- Leakage between chimney and flue

INSUFFICIENT DRAUGHT IN THE CHIMNEY

- Insufficient temperature difference, e.g., due to poorly insulated chimney
- High outside temperature, e.g., in the summer
- Absence of wind
- The chimney is too low and sheltered
- Leaks or other false air in the chimney
- Chimney and flue clogged
- The house lacks ventilation (lack of fresh air supply)
- Negative smoke extraction (poor draft conditions)

With a cold chimney or severe weather conditions, the poor draught can be compensated by supplying the stove with more air than usual.

If the interruptions persists, we recommend that you contact your RAIS dealer or chimneysweep.

SPARE PARTS

If you need new spare parts for your product, you can scan the QR code to see which spare parts we offer. If spare parts other than those recommended by RAIS are used, the warranty will be cancelled. All interchangeable parts can be purchased as spare parts from your RAIS dealer.



SPECIFICATIONS

DTI Ref.: 300-ELAB-2686-EN

 R600RD
R600T

		Nominal	Standard: EN 16510-2-2:2022
		Wood logs	Fuel
P	kW	7.9	Nominal heat output
P _{SH}	kW	7.9	Space heat output
η	%	≥ 75	Efficiency
η _s	%	≥ 65	Seasonal space heat efficiency
EEL	-	105	Class A Energy efficiency index
CO (13% O ₂)	mg/Nm ³	≤ 1500	CO emission at 13 % oxygen content
NO _x (13% O ₂)	mg/Nm ³	≤ 200	NO _x emission at 13 % oxygen content
OGC (13% O ₂)	mg/Nm ³	≤ 120	Hydrocarbon emission at 13 % oxygen content
PM (13% O ₂)	mg/Nm ³	≤ 40	Particulate matter emission at 13 % oxygen content
p	Pa	12	Minimum flue draught
s	mm	50*	Material type and thickness of protective insulation
T _s	°C	382	Flue gas outlet temperature at the flue pipe collar
Tclass	-	T400 G	Chimney designation according to the appropriate chimney standard
Φ _{fg}	g/s	6.2	Flue gas mass flow
V _h	m ³ /h	0	Standing air loss
CON or INT	-	INT	Intermittent operation (INT)
t	min	47	Fuelling time
M _a	kg	1.8	Recommended wood quantity when filling (Divided into 2-3 pieces of firewood)
d _{out}	mm	150	The diameter of the flue pipe collar
L, H, W	mm	721/846/416 (R600RD)	Overall dimensions of the appliance (length, height, width)
		758/846/416 (R600T)	
L _c , H _c , W _c	mm	595/465/274	Combustion chamber (length, height, width)
m	kg	120-125	Mass of the appliance
Type	-	BE	Appliance intended to be supplied with combustion air via a combustion air duct

The fireplace insert was tested and approved by:
 DTI - Danish Technological Institute
 Teknologiparken Kongsvang Allé 29
 8000 Aarhus C, Denmark
 www.dti.dk
 Tel.: +45 7220 2000, Fax: +45 7220 1019

*The material (panels/brick) needs to be complied with an insulation value greater than 0,03 m² x K/W. For more information about installation materials, see the installation section in the installation manual.

Set-up distances		R600RD	R600T	
d_R	mm	200	200	Minimum distance from the rear edge of the door to combustible material
d_S	mm	1000	1000	Minimum distances from the sides to combustible material
d_C	mm	835	835	Minimum distances from the top of the door to combustible material at the ceiling
d_P	mm	1000	1000	Minimum distances from the front to combustible material (Distance to furniture)
d_F	mm	0**		Minimum distances from the front to combustible material in bottom front radiation area
d_L	mm	0**		Minimum distances from the front to combustible material in side front radiation area
d_B	mm	300	300	Minimum distance from the bottom edge of the door to the floor.
d_{non}	mm	50		Minimum distances to non-combustible walls
		Read and follow the user operating instructions		

**0 mm: Since 65 K is not exceeded by radiation on the floor in front and/or on the side wall. Cf. EN16510 Note 3.

Read the section about installation distances.



SHARED FLUE

IMPORTANT! it is **NOT** allowed to connect multiple stoves to the same chimney in the **UK**.

In other countries it is permitted to connect several stoves to the same chimney, provided that the two stoves have the same owner, as in an example where a house has two floors with one stove in the living room and one on the first floor. It is a requirement that the inlets must be positioned so that there is a clearance difference between them of at least 250 mm.

IN CASE OF MARKET CONTROL

The specifications are based on nominal test results. During the nominal test, an ignition and two pre-fires are used to generate a basic glow layer of approximately 350 g prior to the test firing, which includes 1.8 kg of three pieces of firewood. From here, approximately 5 test cycles are carried out, each of which ends when the weight reaches about 50 g. The weight at the end of the cycle must not differ by more than 100 grammes from the previous cycle.

The user manual includes a more detailed description of how to conduct the nominal test.

DECLARATION OF PERFORMANCE



DECLARATION OF CONFORMITY



RATING PLATE

All RAIS/attika stoves have a rating plate indicating the stove's distance to combustibles, efficiency etc. The nameplate can also be found by scanning the QR code.

R600RD



R600T



INSTALLATION DISTANCE IN CASE OF COMBUSTIBLE WALL

To clarify whether the stove installation wall is flammable or otherwise, contact your building architect or local building authorities. Please make sure that objects made of combustible materials (such as furniture) are not placed closer than the distances indicated in the following tables (fire risk).

MINIMUM DISTANCE FOR CEILINGS AND FLOORS

Distance to the ceiling from the top of the door minimum 835 mm. Distance to the floor from the door bottom is minimum 300 mm. There must be a minimum of 500 mm from the upper convection opening to the ceiling.

ENG

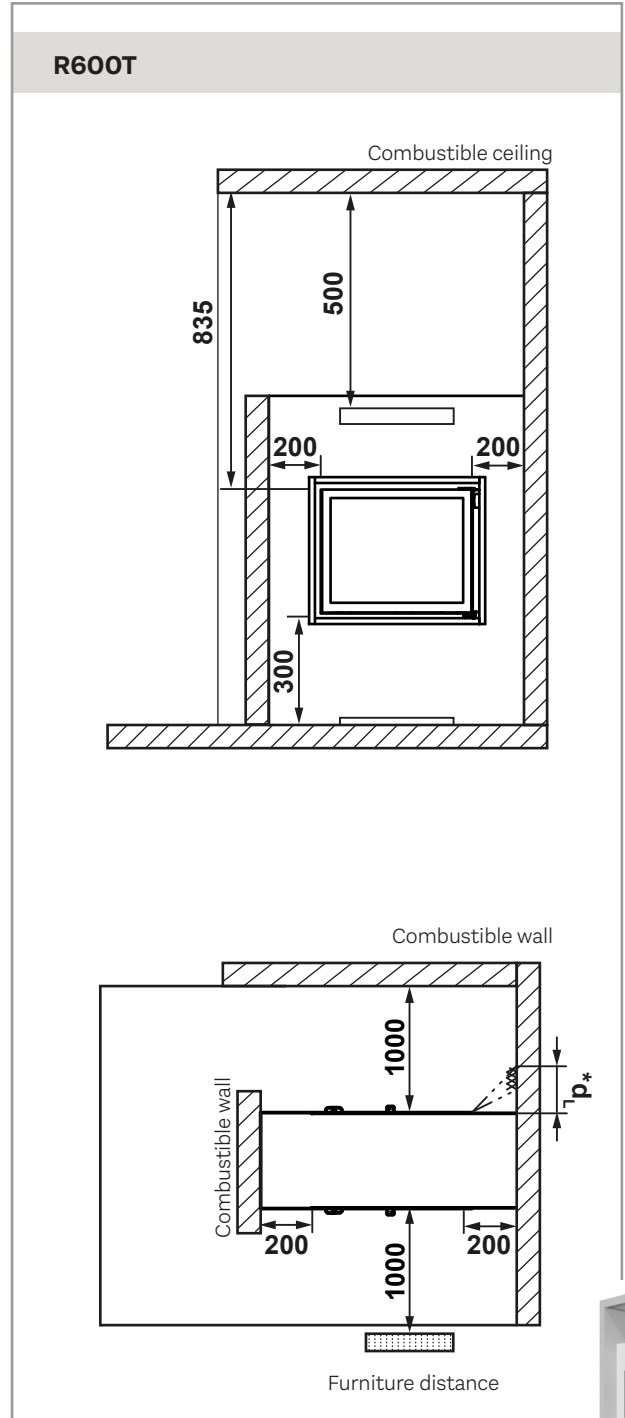
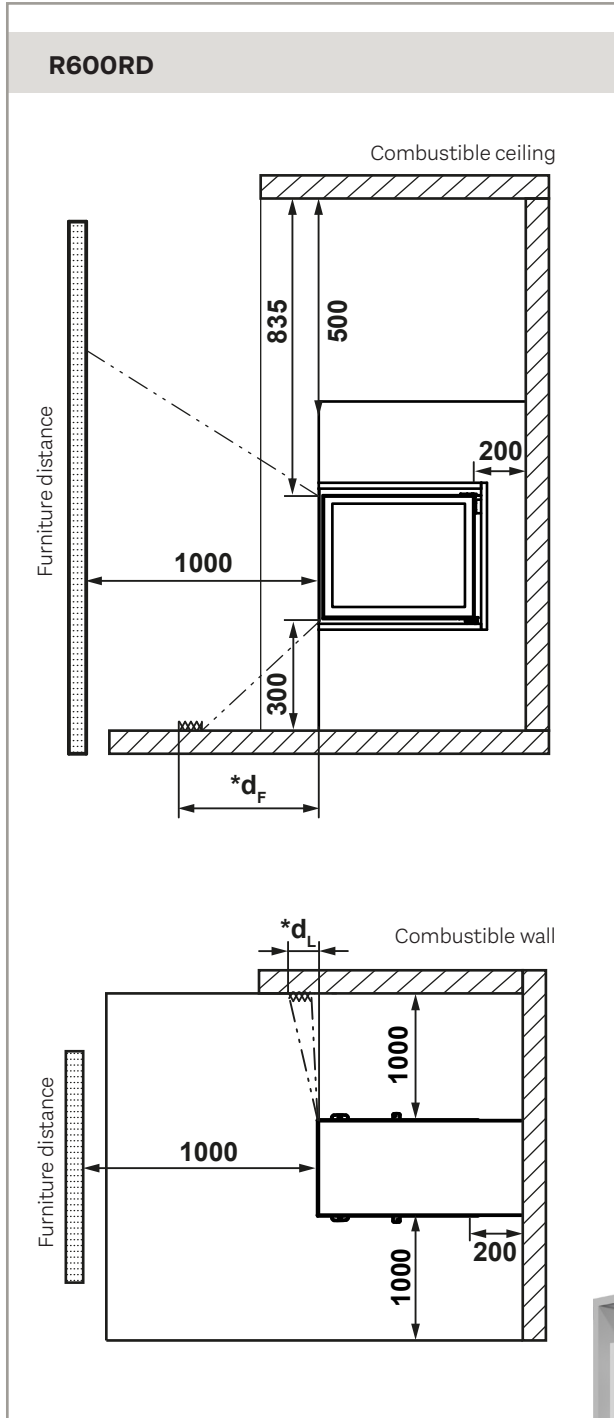

*0 mm: As 65 K is not exceeded by radiation on the floor in front and/or on the side wall.

DIMENSIONAL SKETCHES: R600RD

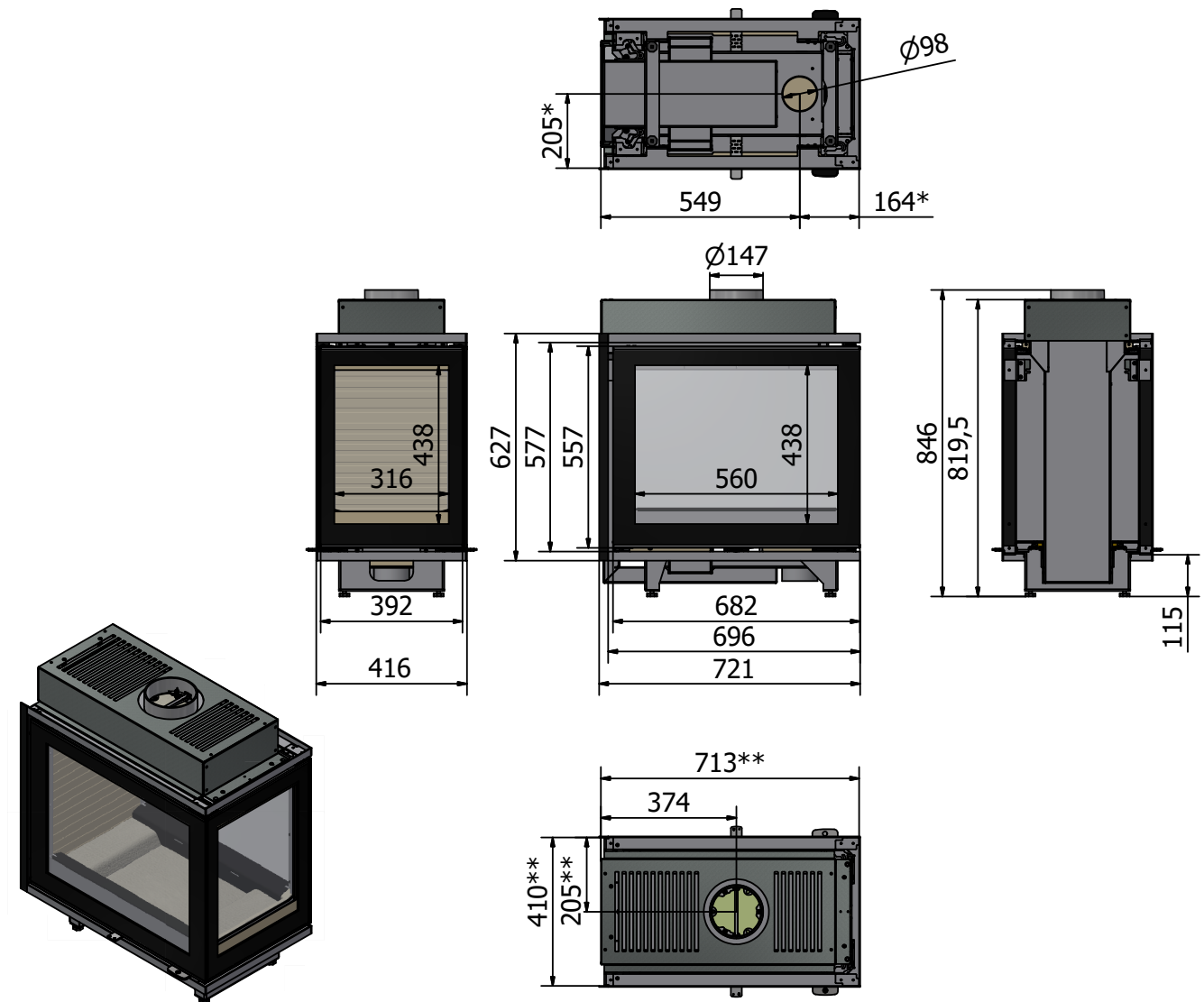

All dimensions are in mm.

*AirSystem

**Inside measure

DIMENSIONAL SKETCHES: R600T

ENG

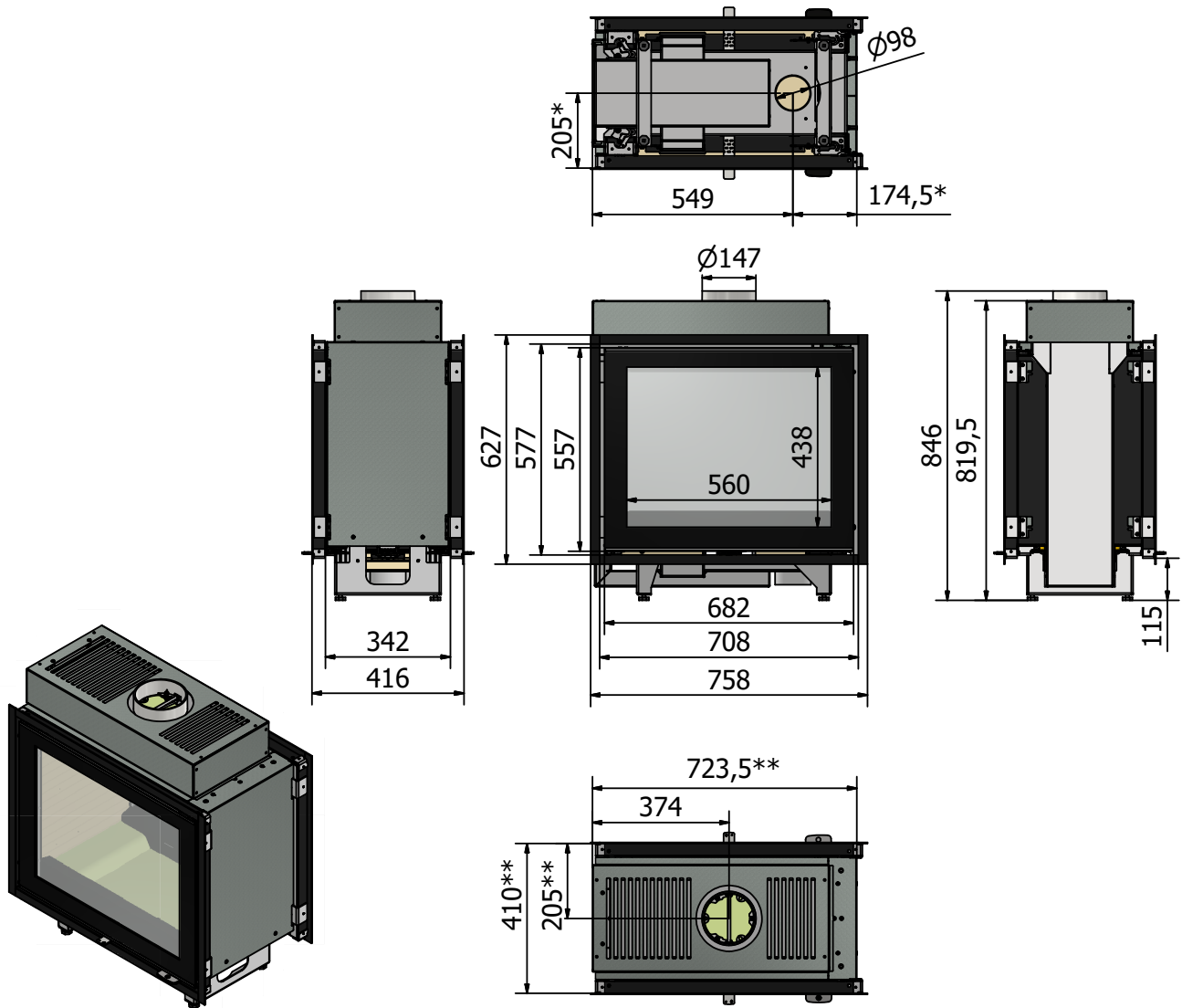

All dimensions are in mm.

*AirSystem

**Indside measure



RECYCLING OF PACKAGING

The fireplace insert is delivered in recyclable packaging. This packaging must be disposed of in accordance with national regulations relating to the disposal of waste.

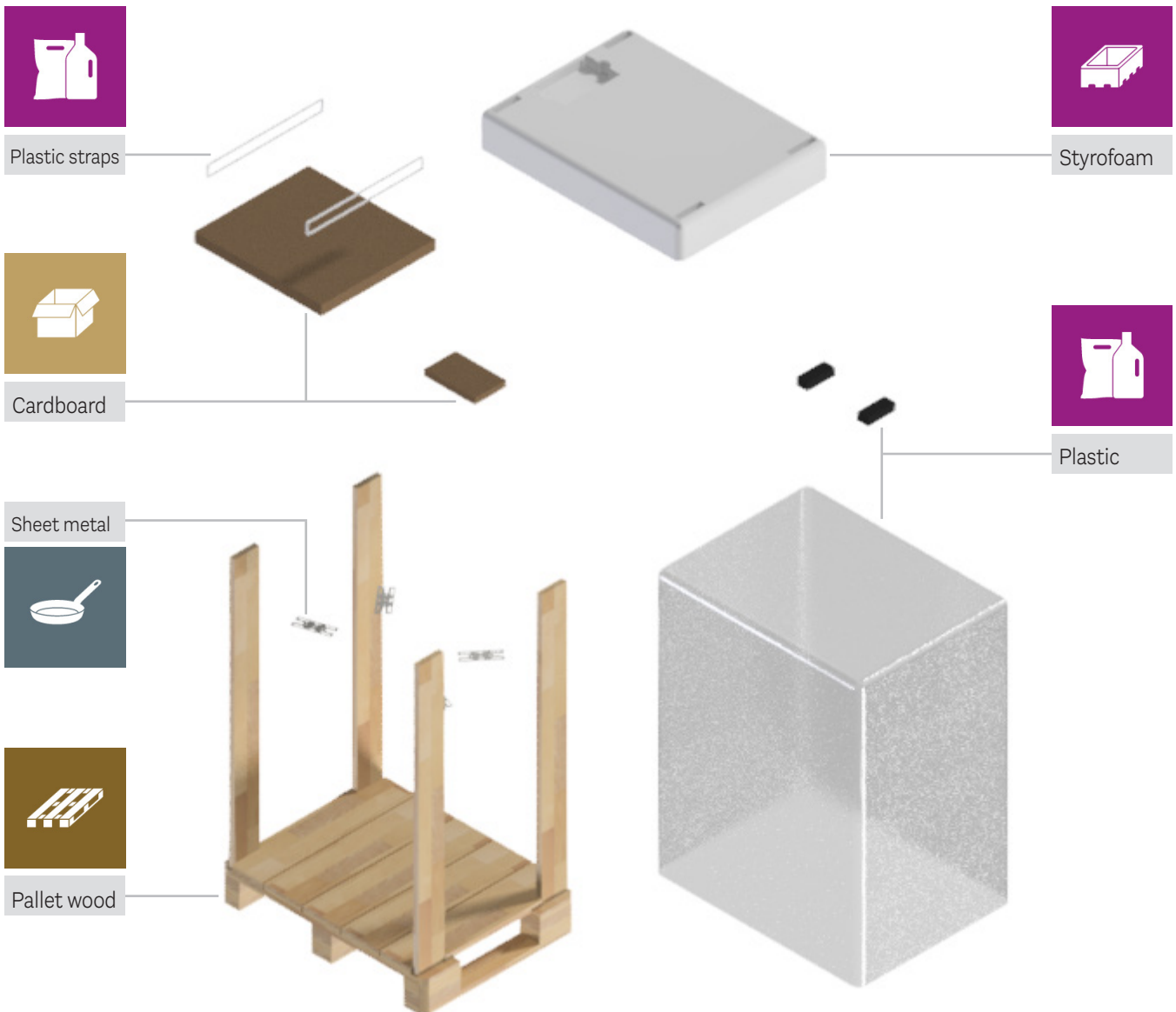

ENG

DISPOSAL AFTER END OF LIFE

When your stove can no longer be used in the distant future, it is important that it is disposed of correctly. At the end of the user manual you will find an overview of how to dispose of the stove itself at the end of its service life.



PACKAGING AT DELIVERY

Upon delivery, the fireplace insert is secured to a transport pallet using four transport safety fittings. The safety fittings are attached with screws which must be unscrewed. The safety fittings can then be removed.

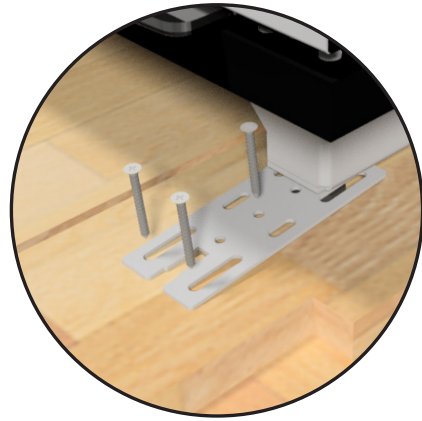

HEIGHT ADJUSTMENT

There are four adjustment screws underneath the appliance. Make sure the stove is level by using the adjustment screws.



REMOVING THE COMBUSTION CHAMBER LINING

To reach the flue, carefully remove the vermiculite smoke deflector plates. To remove the first smoke deflector plate, lift the rear end and tilt the front end down.

Lift one side of the upper smoke deflector plate and tilt the other down. Then, carefully insert in reverse order.

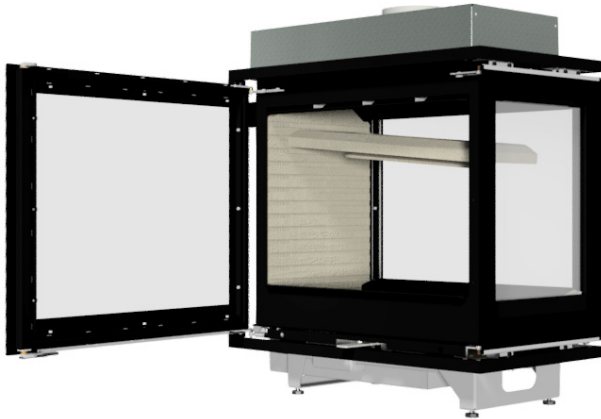

ENG

ATTENTION!

Take care when putting back the smoke deflector plates.



CLEANING AND MAINTENANCE

It is important that the stove is cleaned and maintained both inside and out. When this is done, the stove must be cold. The stove should be inspected by a chimney sweep once a year. Always check the chimney and flue collar for blockages before a heating season. Inspect the exterior and interior of the stove for damage, especially gaskets and the thermal insulation plates (vermiculite).

The combustion chamber lining protects the fireplace insert from heat from the fire. Due to the large temperature variations, cracks may appear in the combustion chamber lining. These can last for several years and should be replaced if they start to crack. The plates are loosely placed inside the combustion chamber and can easily be replaced by you or your dealer. For detailed instructions on how to replace the plates or remove them to clean the flue, see the user manual.

Lubricating door hinges and door locks is a necessary maintenance task that should be done on a regular basis rather than just after damage has occurred. It is advised that you use only our lubricant spray; using other products may cause residue and odour to form. To obtain the lubricant, contact with your dealer.

CHOICE OF MATERIAL FOR INSTALLATION

The material can be panels/brick with an insulation value greater than $0.03 \text{ m}^2 \times \text{K/W}$. The insulation is defined as wall thickness (in metres) divided by the wall's Lambda value. Consult your installation technician/chimney inspector.

During testing, the fireplace insert is installed in a cabinet made of non-flammable 50 mm calcium silicate panels (Skamotec 225). The fireplace insert must be placed on heat-resistant material.

IMPORTANT

As a minimum, the chimney must be constructed of T400-N1-D-50050-G100 flue pipe.

INSTALLATION DIMENSIONS: R600RD

Minimum cavity dimensions (H x W x D) 603 x 410 x 713 mm. A fireplace insert must never be tightly inserted into a cavity, as steel expands when heated.

IMPORTANT

The cavity dimension is the minimum finished dimension. Therefore, remember to take into account plastering and the general structure of the wall so that the dimensions are respected.

When installing against a combustible wall, the installation box must be at least (H x W x D) 1240 x 410 x 880 mm.

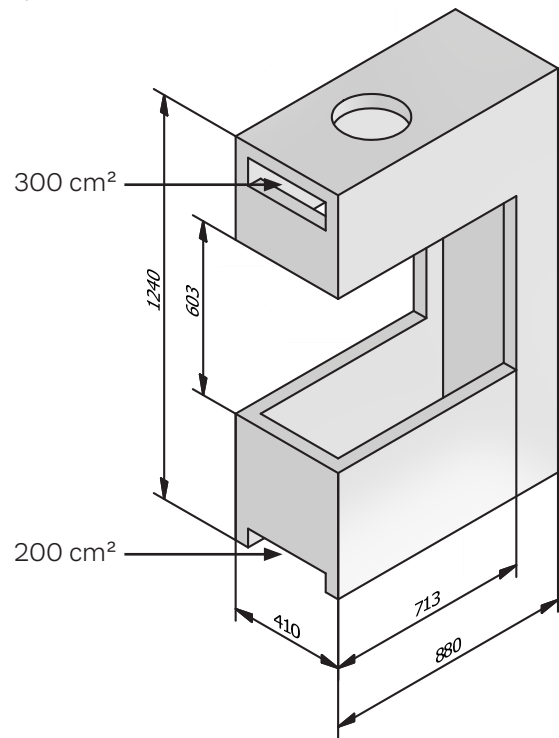
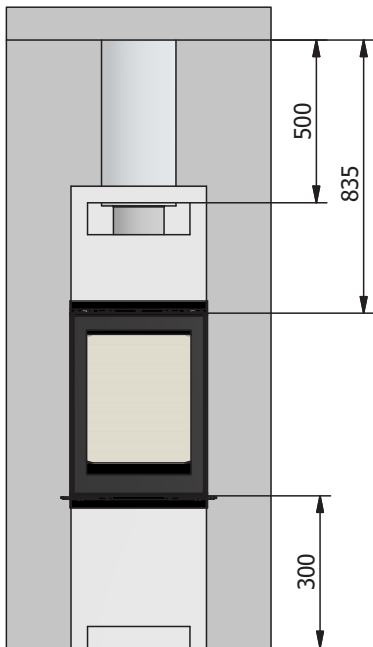

For the safety distances to be applicable, a 50 mm gap filled with stagnant air must be made between the installation box and the combustible wall.

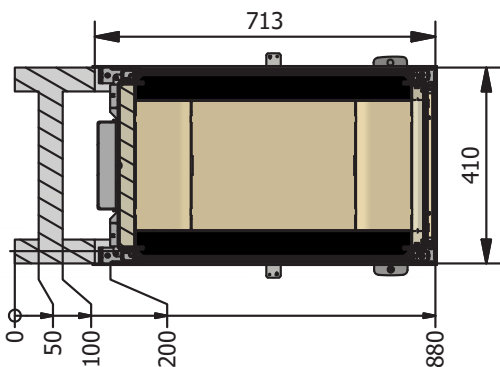
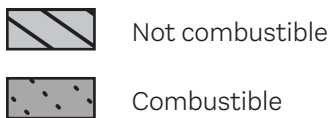

There must be a minimum convection air intake of 200 cm² underneath the stove and 300 cm² above it. The minimum convection-air areas above and below the stove can be distributed over several holes.

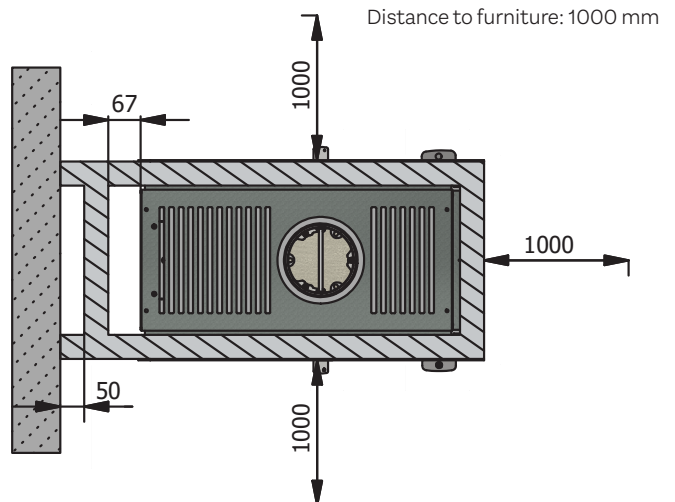

CHOICE OF MATERIAL FOR INSTALLATION

The material can be panels/brick with an insulation value greater than $0.03 \text{ m}^2 \times \text{K/W}$. The insulation is defined as wall thickness (in metres) divided by the wall's Lambda value. Consult your installation technician/chimney inspector.

During testing, the fireplace insert is installed in a cabinet made of non-flammable 50 mm calcium silicate panels (Skamotec 225). The fireplace insert must be placed on heat-resistant material.

ATTENTION!

As a minimum, the chimney must be constructed of T400-N1-D-50050-G100 flue pipe.



INSTALLATION DIMENSIONS: R600T

Minimum cavity dimensions (H x W x D) 603 x 410 x 748 mm. A fireplace insert must never be tightly inserted into a cavity, as steel expands when heated.



IMPORTANT

The cavity dimension is the minimum finished dimension. Therefore, remember to take into account plastering and the general structure of the wall so that the dimensions are respected.

When installing against a combustible wall, the installation box must be at least (H x W x D) 1240 x 410 x 1082 mm.

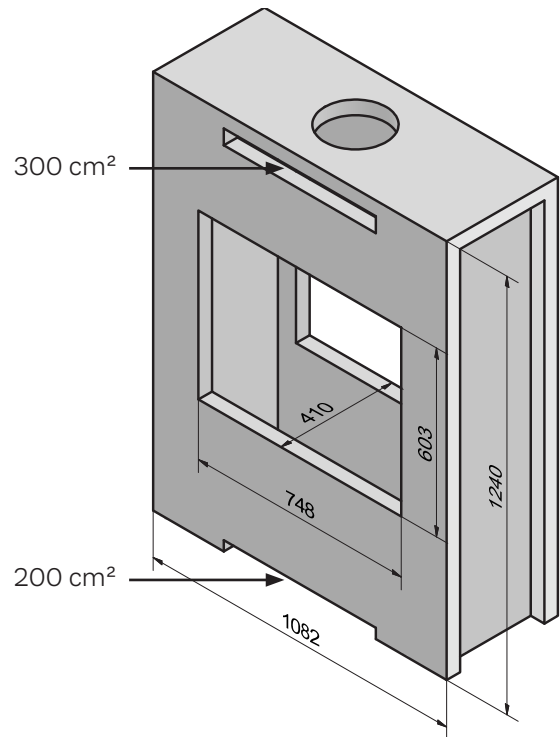
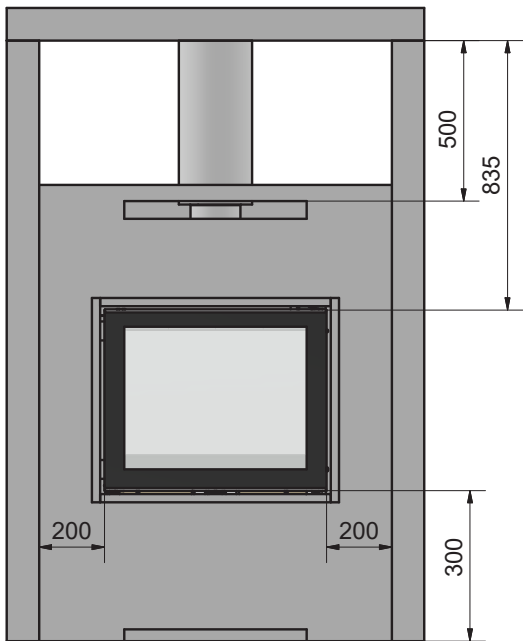

For the safety distances to be applicable, a 50 mm gap filled with stagnant air must be made between the installation box and the combustible wall.

- Not combustible
- Combustible

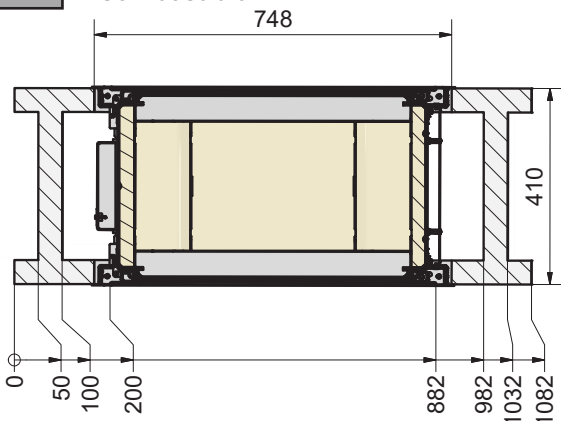

There must be a minimum convection air intake of 200 cm² underneath the stove and 300 cm² above it. The minimum convection-air areas above and below the stove can be distributed over several holes.

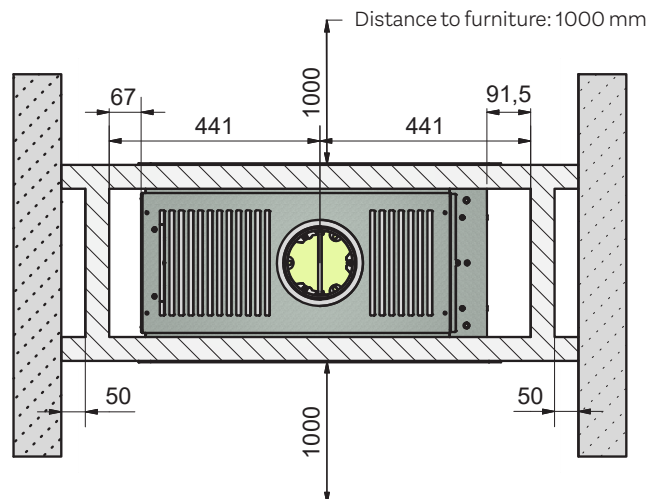

A non-combustible plate must be placed directly above the convection opening to prevent "standing" hot air. This is done to protect the ceiling and direct hot air from the cassette.

ENG

UN-INSULATED FLUE:

ATTENTION!
The insulated chimney must pass through the non-combustible plate.

Non-combustible plate

Combustible wall

DISTANCE	DIMENSIONS MM
Furniture from the door	1000
Furniture from the front	1000

INSULATED FLUE:

ATTENTION!
The insulated chimney must extend all the way to the flue outlet adapter.

Non-combustible plate

Combustible wall

DISTANCE	DIMENSIONS MM
Furniture from the door	1000
Furniture from the front	1000

A non-combustible plate must be placed directly above the convection opening to prevent "standing" hot air. This is done to protect the ceiling and direct hot air from the cassette.

REAR EXIT:



ATTENTION!

The same rules for uninsulated and insulated chimneys apply to rear exit.

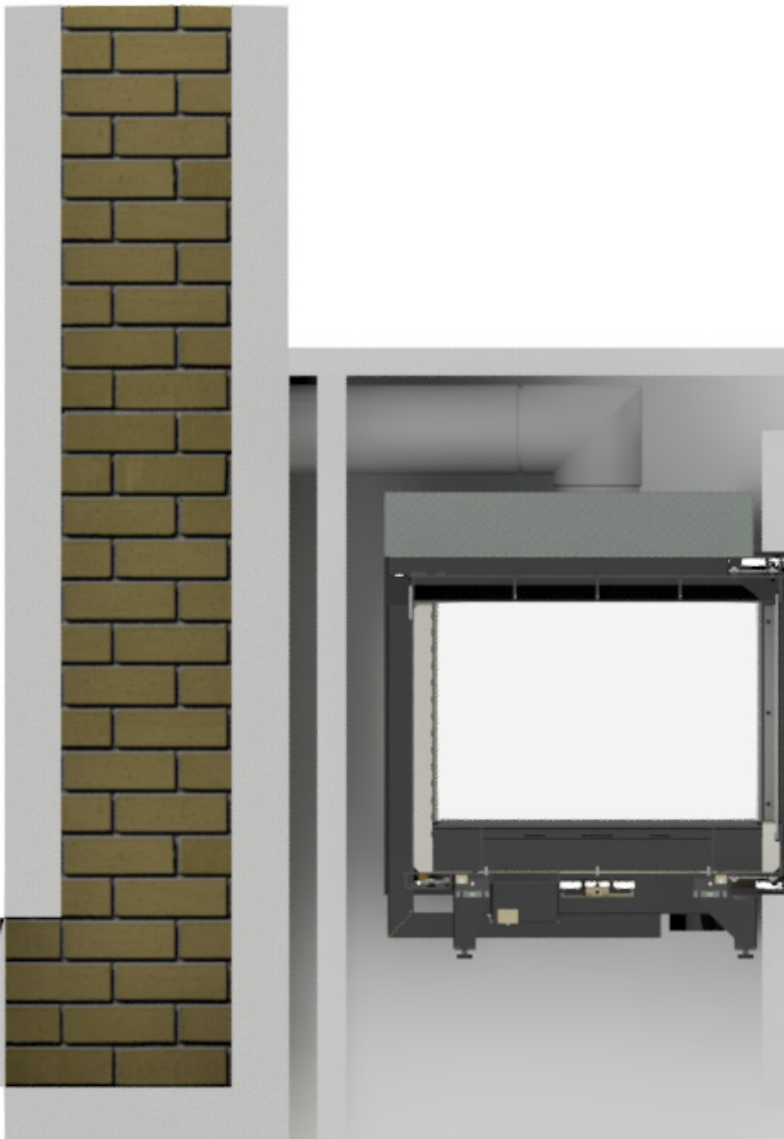

DISTANCE	DIMENSIONS MM
Furniture from the door	1000
Furniture from the front	1000

When the stove is installed in a construction where direct combustion air is required, external air must be connected to the stove from the outside. All RAIS/attika stoves have the option to supply external air.

This external air supply is what we call AirSystem. The air intake for the system can be hidden by installing it either in the floor or in the wall behind the stove.

To ensure that the AirSystem works, it is important to ensure that no negative pressure can build up in the home. It is also important that the convection openings are not blocked.

The maximum length of the flex hose is 5 metres. It is important that it is not bent and folded around corners so that the tube collapses and the airflow cannot get through as intended.

If the air supply is 5-10 metres from the stove, use a Ø120 mm flex hose instead.

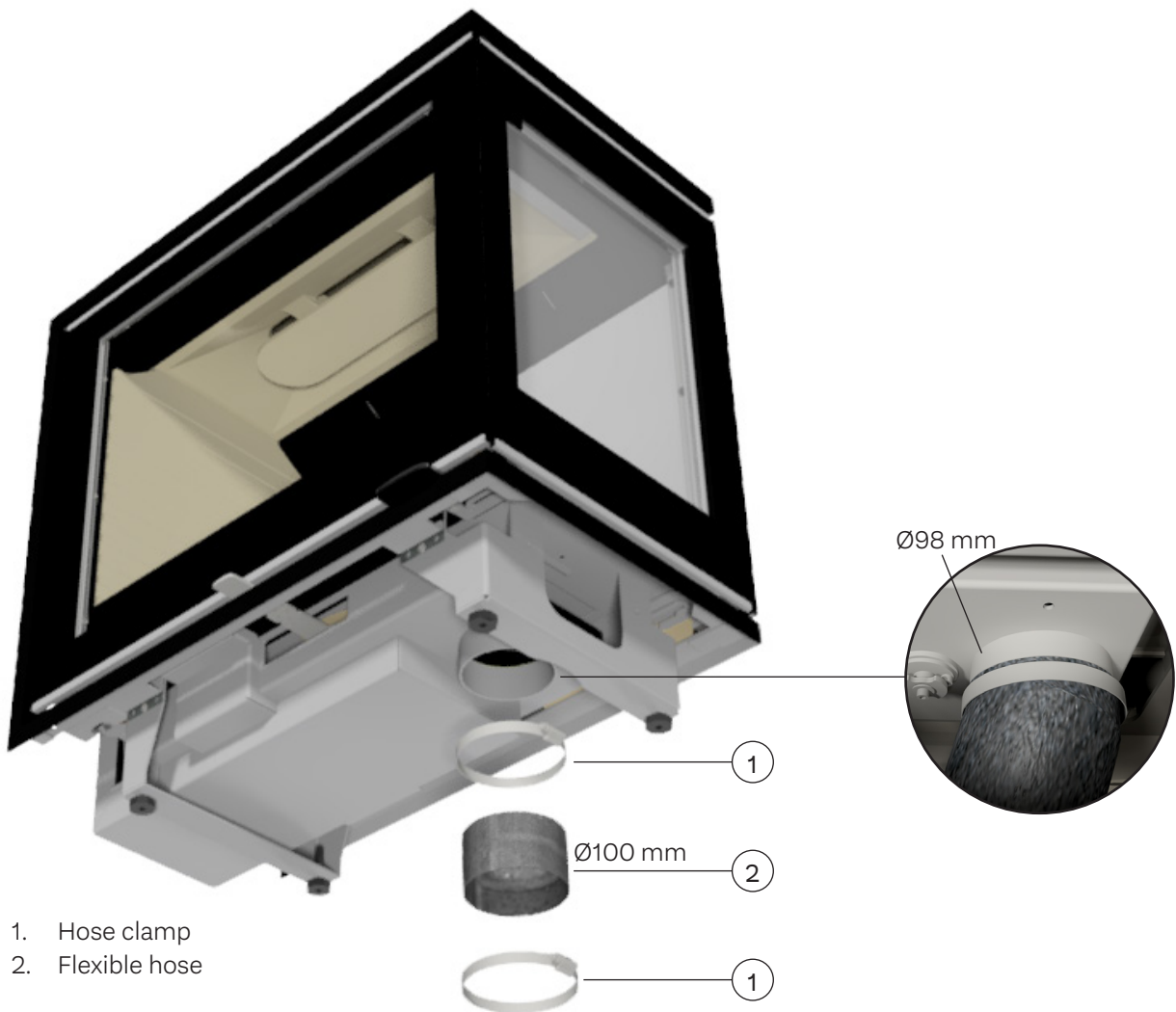

DISMOUNTING FRAMES

It is possible to remove the frames on the stove if it is desired to plaster the wall behind the frames. Follow the following steps:

- 1 There is a cover at the bottom of the stove that must be removed before the frames can be loosened. Open the door and follow these steps to remove the four screws.

NO TAPE ON THE FRAMES

Under no circumstances should tape be applied to the frames, as this will damage the paintwork. RAIS/Attika accepts no responsibility for damage caused by the use of tape.



2 x screws loosened

Cover can be removed



Behind the cover there are 2 x screws that can be loosened



- 2 Next, remove the three screws to release the side frame. There is a screw at the bottom, side and top, as shown in the image below.

Loosen the outer screw at the bottom of the frame

Loosen the screw in the side

Loosen the outer screw at the top of the frame

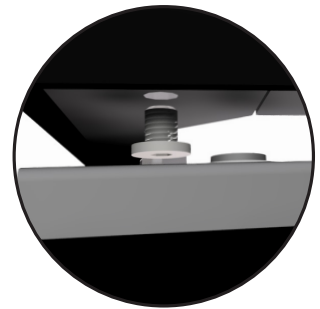
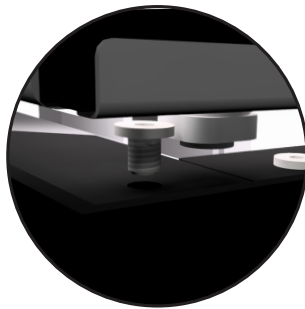

**ATTENTION!**

Since the stove needs room to expand, it is crucial to follow the installation dimensions for the hole dimensions. To ensure that the dimensions are followed, don't forget to consider the plaster and overall wall structure.

- ③ The side frame can now be removed. Repeat the same procedure on the other side. The bottom end frame can also be removed.

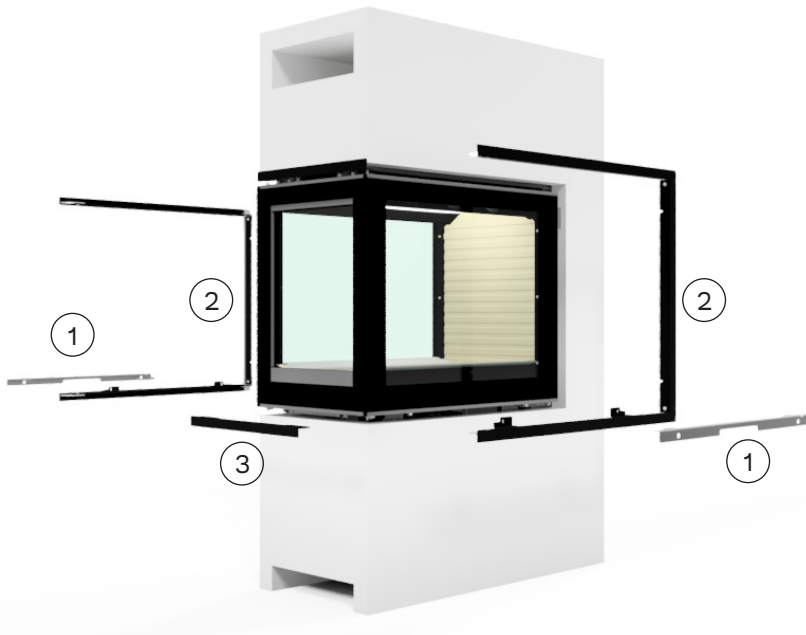

- ④ Remove the entire end glass with the top frame by loosening the four screws.



At the top of the end frame, loosen 2 x screws

At the bottom of the end frame, loosen 2 x screws

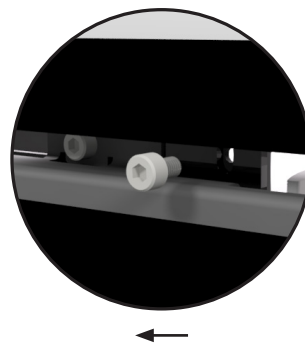

The frames are mounted again in reverse order.

PERMANENT AIR SUPPLY

The appliance needs a permanent air supply to the room of installation as the appliance is over 5kW, confer with Building regulation Approved Document J.

Permanently open air vents should be non-adjustable, sized to admit sufficient air for the purpose intended and positioned where they are unlikely to become blocked. see Approved Document J.

A CO Alarm must be fitted into the same room as the appliance upon installation. The alarm shall be compliant with British Standards BS 50291. Where battery powered alarms are selected, alarms with 'sealed for life' batteries rather than alarms with replaceable batteries are the better option.

THE CLEAN AIR ACT 1993 AND SMOKE CONTROL AREAS

Under the clean air act local authorities may declare the whole or part of the district of the authority to be a smoke control area. It is an offence to emit smoke from a chimney of a building, from a furnace or from any fixed boiler if located in a designated smoke control area. It is also an offence to acquire an "unauthorised fuel" for use within a smoke control area unless it is used in an "exempt" appliance ("exempted" from the controls which generally apply in the smoke control area).

In England appliances are exempted by publication on a list by the secretary of state in accordance with changes made to sections 20 and 21 of the clean air act 1993 by section 15 of the deregulation act 2015. In Scotland appliances are exempted by publication on a list by Scottish ministers under section 50 of the regulatory reform (Scotland) act 2014. Similarly, in Northern Ireland appliances are exempted by publication on a list by the department of agriculture, environment and rural affairs under section 16 of the environmental better regulation act (Northern Ireland) 2016. In Wales appliances are exempted by regulations made by Welsh ministers.

The secretary of state for environment, food and rural affairs has powers under the act to authorize smokeless fuels or exempt appliances for use in smoke control areas in England. In Scotland and Wales this power rests with the ministers in the devolved administrations for those countries. Separate legislation, the clean air (Northern Ireland) order 1981, applies in Northern Ireland. Therefore it is a requirement that fuels burnt or obtained for use in smoke control areas have been "authorised" in regulations and that appliances used to burn solid fuel in those areas (other than "authorised"

fuels) have been exempted by an order made and signed by the secretary of state or minister in the devolved administrations.

FUEL OVERLOADING

The maximum amount of fuel specified in this manual should not be exceeded, overloading can cause excess smoke.

REFUELLING ON TO A LOW FIRE BED

If there is insufficient burning material in the firebed to light a new fuel charge, excessive smoke emission can occur. Refuelling must be carried out onto a sufficient quantity of glowing embers and ash that the new fuel charge will ignite in a reasonable period. If there are too few embers in the fire bed add suitable kindling to prevent excess smoke.

DAMPERS LEFT OPEN

Operation with the air control or appliance dampers open can cause excess smoke. The appliance must not be operated with air controls, appliance dampers or door left open except as directed in the instructions.

OPERATION WITH DOOR LEFT OPEN

Operation with the door open can cause excess smoke. The appliance must not be operated with the appliance door left open except as directed in the instructions.

**ATTENTION!**

This page is only relevant for appliances installed in United Kingdom.



Article number: 23-6520ENG



5 708252 430518

RAIS[®]

RAIS A/S
Industrivej 20
DK-9900 Frederikshavn
Denmark
www.rais.com

attika[®]
FEUERKULTUR

ATTIKA FEUER AG
Brunnmatt 16
CH-6330 Cham
Switzerland
www.attika.ch