



## VISIO 3:1

INSTALLATION MANUAL (ENGLISH)

**RAIS**<sup>®</sup>

attika<sup>®</sup>  
FEUERKULTUR

**PRODUCTION NUMBER**

The production number can be found on the frame under the door and at one of the front pages of the user manual.

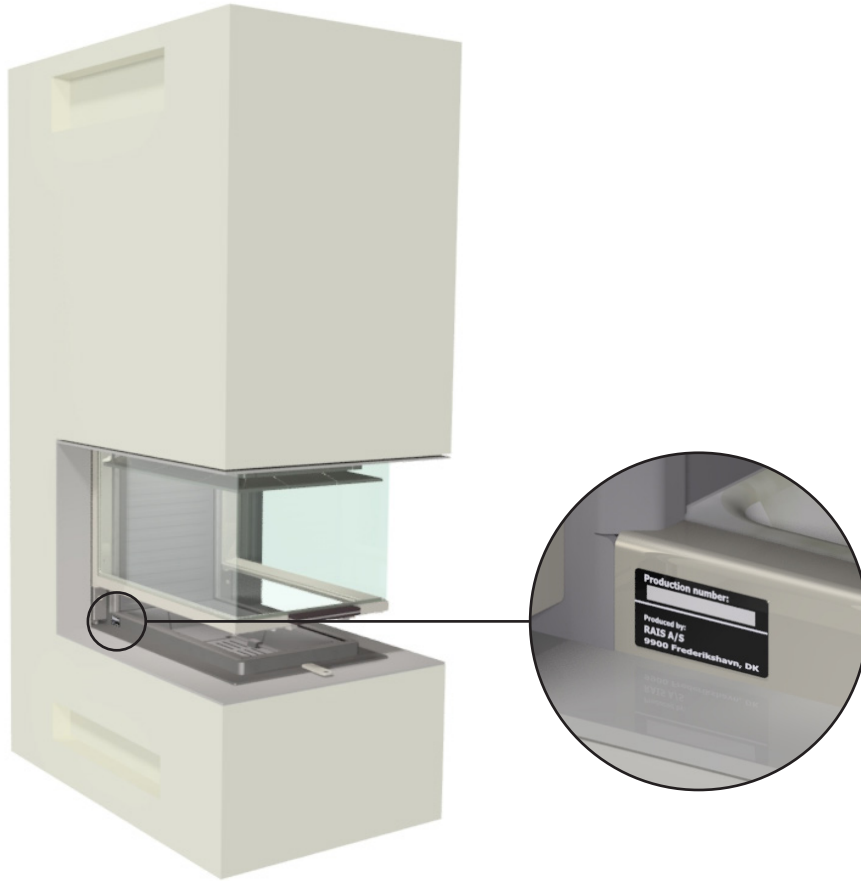

**THIS MANUAL APPLIES TO THE FOLLOWING MODELS:**

- Visio 3:1

Visio 3:1



# CONTENT

PRODUCTION NUMBER	2
INSTALLATION MANUAL	4
Malfunctions .....	5
TECHNICAL DATA	6
Specifications .....	6
INSTALLATION DISTANCE	8
DIMENSIONAL SKETCHES	10
INSTALLATION	
Recycling of packaging .....	11
Packaging at delivery .....	12
Height adjustment .....	12
Reflector plate .....	13
Transport lock .....	13
Changing the flue outlet direction .....	14
Removing the combustion chamber lining .....	15
Cleaning and maintenance .....	15
Service hatch .....	16
Heat distributor .....	17
INSTALLATION DIMENSIONS	
Installation dimensions .....	18
No tape on the frames .....	18
Convection vents .....	18
Choice of material for installation .....	18
Installation dimensions: without frame .....	19
Installation dimensions: with frame .....	20
Distance to flammable material with wall moved forward .....	21
CONVERT TO SELF-CLOSING DOOR	22
EXTERNAL AIR CONNECTION - AIRSYSTEM	26
SPECIAL PRECAUTIONS FOR INSTALLATION IN UK	27

Revision: 0  
Date: 09-10-2025

We reserve the right to make printing errors.

**INSTALLATION GUIDE**

Thank you for choosing your new RAIS or ATTIKA product! This installation instructions manual will ensure that your fireplace insert is installed correctly and that it will provide you with comfort and pleasure for many years to come.

**GENERAL**

It is important to correctly install the fireplace insert out of consideration for both the environment and personal safety. The installation must comply with all local rules and regulations, including those that refer to national and European standards. A certified chimney sweeper should be contacted before set-up. No unauthorised alterations may be made to the fireplace insert.

Upon receipt, inspect the fireplace for any transport damage. Do not install the fireplace until you have checked it thoroughly. First remove the transport screws, more info on this on page 13. It is important that the door and damper functions, as well as a visual check of the frame and door of this fireplace insert are checked and tested **BEFORE** installation.

**FLOOR CONSTRUCTION**

The floor structure must be able to support the weight of the fireplace insert and a chimney, if required. If the existing floor structure does not meet this requirement, suitable measures must be taken (e.g. installation of a load distribution plate). If in doubt, contact a building expert.

National and local regulations must be complied with, including the size of the non-flammable plate that must cover the flammable floor in front of the fireplace insert to protect the floor from falling embers.

**DISTANCE TO COMBUSTIBLE MATERIAL**

The fireplace insert must be positioned at a safe distance from flammable material. Due to risk of fire, flammable items (e.g. furniture) may not be positioned closer to the insert than specified in the sections on placement. When deciding where to install your RAIS/ATTIKA fireplace insert, you should consider being able

to heat other rooms in your home to get the most out of your new fireplace insert.

**VENTILATING SYSTEMS**

The fireplace needs permanent and sufficient air to operate safely and efficiently. A permanent air supply can be installed in the room for the fireplace's combustion air - through the AirSystem connection. Under no circumstances should this air supply be closed during operation. Note that any mechanical extraction such as a cooker hood can reduce the air supply. The fireplace has an air consumption of min. 29.3 m<sup>3</sup>/h.

**CHIMNEY**

As a minimum, the chimney must be constructed of T400-N1-D-50050-G100 flue pipe, and be tall enough that the draft conditions are in order, i.e. 12 pascal to 18 pascal. If the recommended chimney draught cannot be achieved, problems of smoke puffing from the door may arise when heating. The collar is 200 mm in diameter. Remember: there must be unobstructed access to the access door on the chimney.

If the draught is too strong, it is advisable to equip the chimney with a regulating damper. If a regulating damper is fitted, you must ensure that there is a free flow-through area of at least 20 cm<sup>2</sup> when the regulating damper is closed.

The length of the chimney, calculated from the top of the fireplace insert should not be less than 3 metres and must be at least 80 cm above the roof ridge. If the chimney is placed on the side of the house, the top of the chimney must never be lower than the roof ridge or the roof's highest point. Note that there are often national and local regulations relating to houses with thatched roofs.

Always make sure to comply with applicable standards (EN 15287-1:2023 and EN 15287-2:2023) for chimney installation. It is also important to check the correct functioning of the chimney according to EN 13384-2:2015+A1:2019 based on the individual solution on site

**ATTENTION!**

The appliance shall not be installed with ventilating systems which have pressure below -15 Pa.



**ATTENTION!**

Before the fireplace insert may be put to use, the set-up must be reported to your local chimney sweeper.



**ATTENTION!**

RAIS/ATTIKA recommends having the insert installed by an authorised technician. Please ask your dealer for further information.

**MALFUNCTIONS**

If you are experiencing disturbances, some of the most common causes are listed below.

**SMOKE SPILLAGE AROUND THE DOOR**

- This may be due to insufficient draft in the chimney <math><12\text{Pa}</math>
- Check whether the flue or chimney is blocked
- Check whether the hood is switched on and, if so, switch it off and open a window / door near the fireplace for a short period.

**SOOT ON GLASS**

- Excessively wet firewood
- The damper regulation is too low
- Ensure proper heating of the fireplace when lighting, prior to closing the door

**FIREPLACE IS BURNING TOO STRONG**

- Leak around the door seal
- Chimney draft too large >18 Pa, draft regulator should be installed.
- The damper is not regulated down enough

**FIREPLACE IS BURNING TOO WEAK**

- Insufficient wood
- Insufficient air supply for room ventilation
- Unclean smoke flue
- Leaky chimney
- Leakage between chimney and flue

**INSUFFICIENT DRAUGHT IN THE CHIMNEY**

- Insufficient temperature difference, e.g., due to poorly insulated chimney
- High outside temperature, e.g., in the summer
- Absence of wind
- The chimney is too low and sheltered
- Leaks or other false air in the chimney
- Chimney and flue clogged
- The house lacks ventilation (lack of fresh air supply)
- Negative smoke extraction (poor draft conditions)

With a cold chimney or severe weather conditions, the poor draught can be compensated by supplying the fireplace with more air than usual.

If the interruptions persists, we recommend that you contact your RAIS dealer or chimneysweep.

**SPARE PARTS**

You can view the spare parts we offer by scanning the QR code if you need new ones for your product. The warranty disappears if replacement parts are used that are not recommended by RAIS. Your RAIS dealer is able to provide spare parts for all interchangeable parts.



## SPECIFICATIONS

DTI Ref.: 300-ELAB-2287-EN

		Nominal	Standard: EN16510-2-2:2022
		Wood logs	Fuel
P	kW	10.0	Nominal heat output
P <sub>SH</sub>	kW	10.0	Space heat output
η	%	≥ 75	Efficiency
η <sub>s</sub>	%	≥ 65	Seasonal space heat efficiency
EEl	-	106	Class A Energy efficiency index
CO (13% O <sub>2</sub> )	mg/Nm <sup>3</sup>	≤ 1500	CO emission at 13 % oxygen content
NO <sub>x</sub> (13% O <sub>2</sub> )	mg/Nm <sup>3</sup>	≤ 200	NO <sub>x</sub> emission at 13 % oxygen content
OGC (13% O <sub>2</sub> )	mg/Nm <sup>3</sup>	≤ 120	Hydrocarbon emission at 13 % oxygen content
PM (13% O <sub>2</sub> )	mg/Nm <sup>3</sup>	≤ 40	Particulate matter emission at 13 % oxygen content
p	Pa	12	Minimum flue draught
s	mm	50*	Material type and thickness of protective insulation
T <sub>s</sub>	°C	299	Flue gas outlet temperature at the flue pipe collar
Tclass	-	T400 G	Chimney designation according to the appropriate chimney standard
Φ <sub>f,g</sub>	g/s	10.1	Flue gas mass flow
V <sub>h</sub>	m <sup>3</sup> /h	0	Standing air loss
CON or INT	-	INT	Intermittent operation (INT)
t	min	47	Fuelling time
M <sub>a</sub>	kg	2.3	Recommended wood quantity when filling (Divided into 3-4 pieces of firewood)
d <sub>out</sub>	mm	200	The diameter of the flue pipe collar
L, W, H	mm	929 x 628 x 1368	Overall dimensions of the appliance (length, height, width)
L <sub>c</sub> , W <sub>c</sub> , H <sub>c</sub>	mm	499 x 210 x 230**	Combustion chamber (length, height, width)
m	kg	260	Mass of the appliance
Type	-	BE	Appliance intended to be supplied with combustion air via a combustion air duct

\*The material (panels/brick) needs to be complied with an insulation value greater than 0,03 m<sup>2</sup> x K/W. For more information about installation materials, see the installation section in the installation manual.

\*\*Max. load limit

The fireplace insert was tested and approved by:  
 DTI - Danish Technological Institute  
 Teknologiparken Kongsvang Allé 29  
 8000 Aarhus C, Denmark  
 www.dti.dk  
 Tel.: +45 7220 2000, Fax: +45 7220 1019

Set-up distances		Visio 3:1	
$d_R$	mm	0	Minimum distance from the back of the installation box to combustible material
$d_S$	mm	700	Minimum distances from the sides to combustible material
$d_C$	mm	420	Minimum distance from top convection opening to combustible material in the ceiling
$d_P$	mm	700	Minimum distances from the front to combustible material (Distance to furniture)
$d_F$	mm	0*	Minimum distances from the front to combustible material in bottom front radiation area
$d_L$	mm	0*	Minimum distances from the front to combustible material in side front radiation area
$d_B$	mm	375	Minimum distance from the bottom edge of the door to the floor.
$d_{non}$	mm	0	Minimum distances to non-combustible walls
			Read and follow the user operating instructions

\*0 mm: Since 65 K is not exceeded by radiation on the floor in front and/or on the side wall. Cf. EN16510 Note 3.

**SHARED FLUE**

**IMPORTANT!** it is **NOT** allowed to connect multiple fireplaces to the same chimney in the **UK**.

In other countries it is permitted to connect several fireplaces to the same chimney, provided that the two fireplaces have the same owner, as in an example where a house has two floors with one fireplace in the living room and one on the first floor. It is a requirement that the inlets must be positioned so that there is a clearance difference between them of at least 250 mm. This is only allowed if the door is self-closing, so read the relevant section in the installation manual carefully.



**IN CASE OF MARKET CONTROL**

The specifications are based on nominal test results. During the nominal test, an ignition and two pre-fires are used to generate a basic glow layer of approximately 480 g prior to the test firing, which includes 2.3 kg of three pieces of firewood. From here, approximately 5 test cycles are carried out, each of which ends when the weight reaches about 30 g. The weight at the end of the cycle must not differ by more than 100 grammes from the previous cycle.

The user manual includes a more detailed description of how to conduct the nominal test.

**DECLARATION OF PERFORMANCE**



**DECLARATION OF CONFORMITY**



**RATING PLATE**

All RAIS/attika fireplaces have a rating plate indicating the fireplace's distance to combustibles, efficiency etc. The nameplate can also be found by scanning the QR code.



**INSTALLATION DISTANCE IN CASE OF COMBUSTIBLE WALL**

To clarify whether the fireplace installation wall is flammable or otherwise, contact your building architect or local building authorities. Please make sure that objects made of combustible materials (such as furniture) are not placed closer than the distances indicated in the following tables (fire risk).

**MINIMUM DISTANCE FOR CEILINGS AND FLOORS**

Distance to the floor from the door bottom is minimum 375 mm. There must be a minimum of 420 mm from the upper convection opening to the ceiling.

ENG

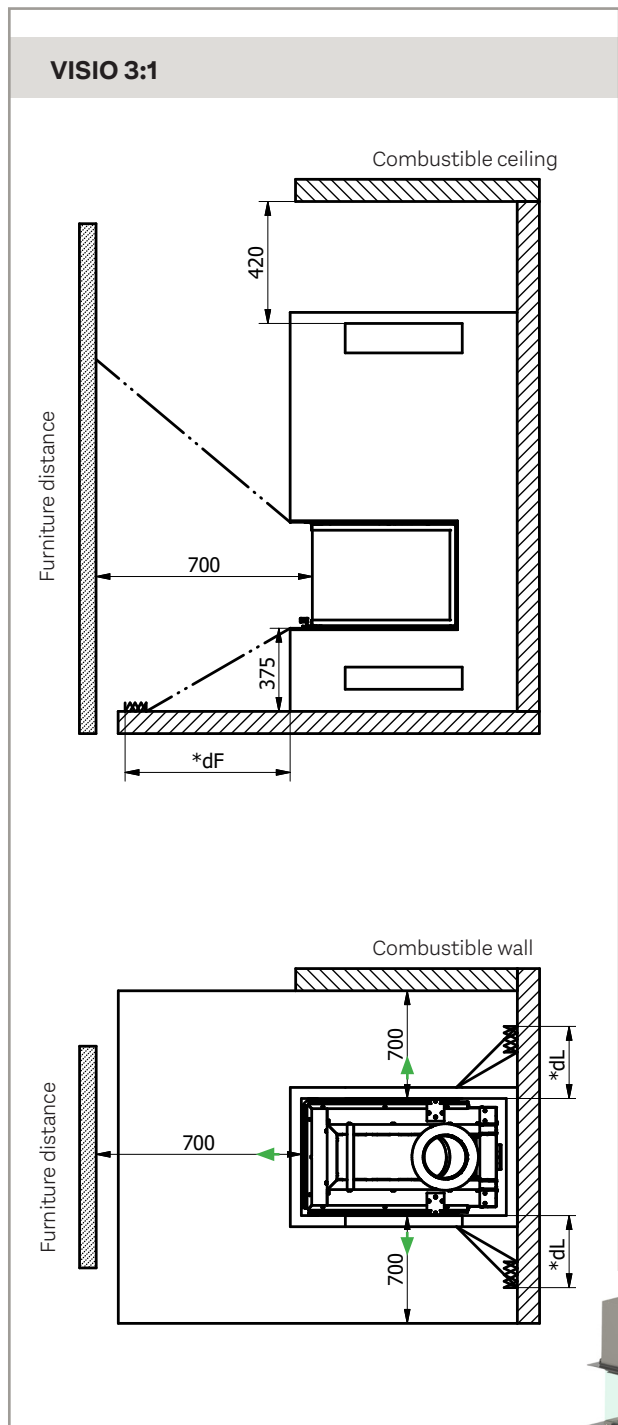

\*0 mm: As 65 K is not exceeded by radiation on the floor in front.

DIMENSIONAL SKETCHES: WITHOUT FRAME

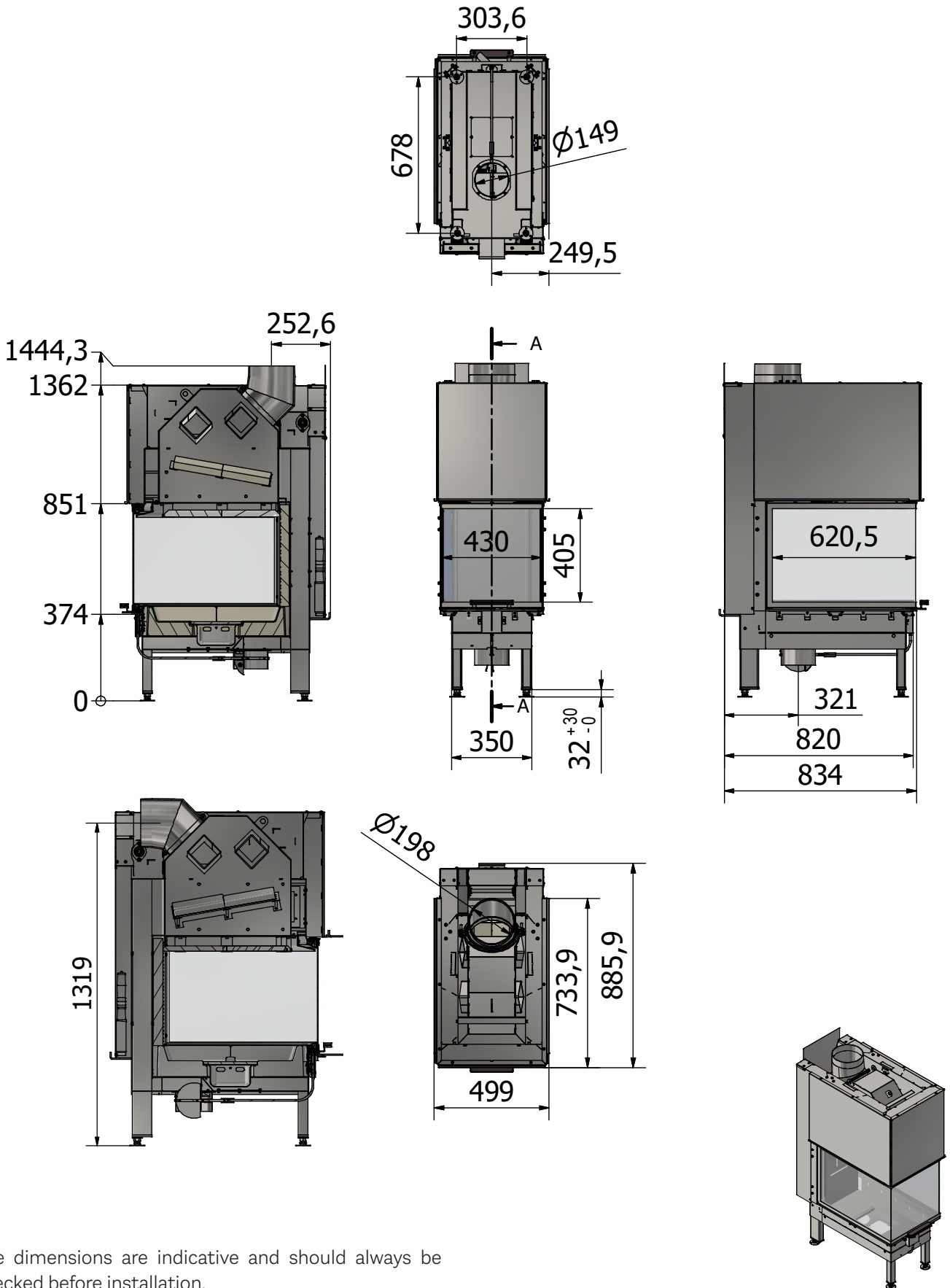

The dimensions are indicative and should always be checked before installation.

DIMENSIONAL SKETCHES: WITH FRAME

ENG

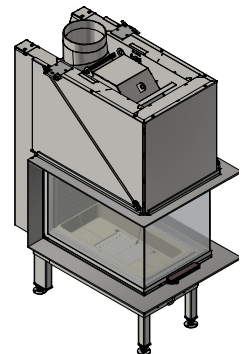
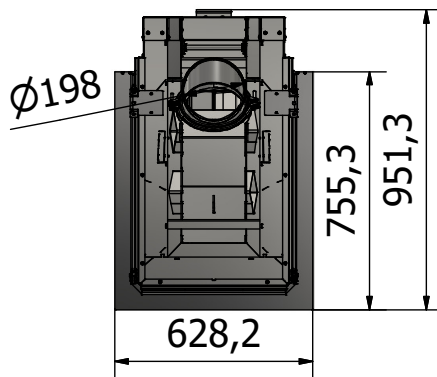
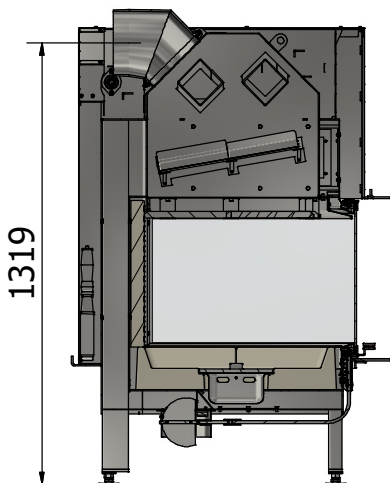
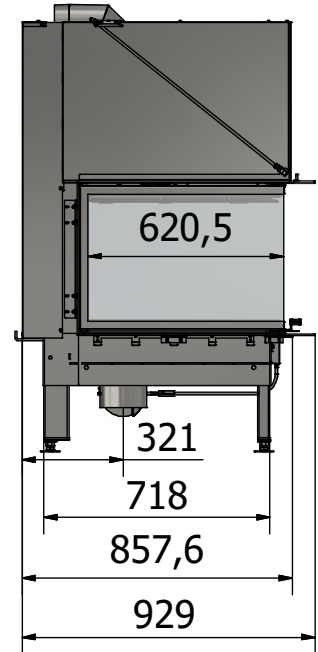
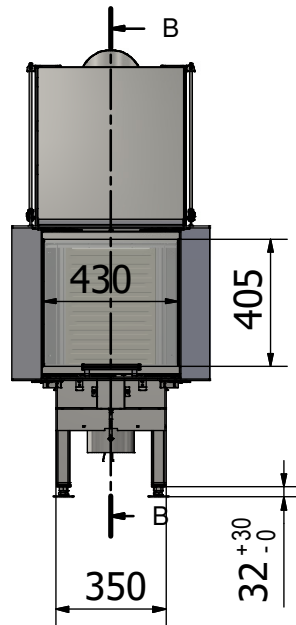
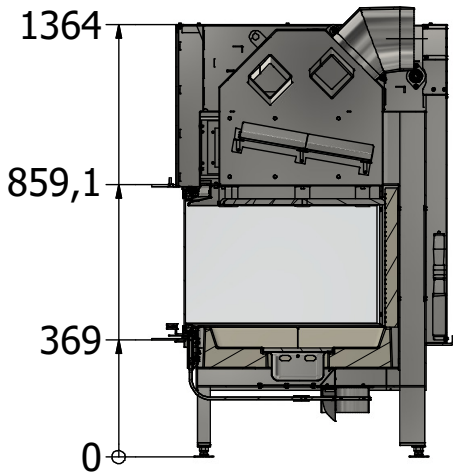
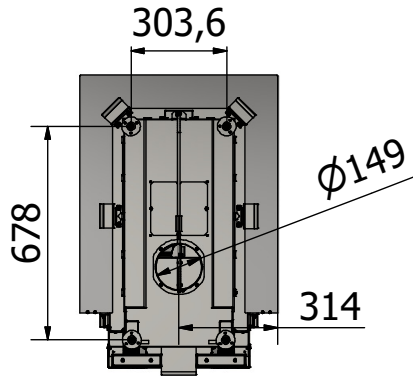

The dimensions are indicative and should always be checked before installation.



**RECYCLING OF PACKAGING**

The fireplace insert is delivered in recyclable packaging. This packaging must be disposed of in accordance with national regulations relating to the disposal of waste.

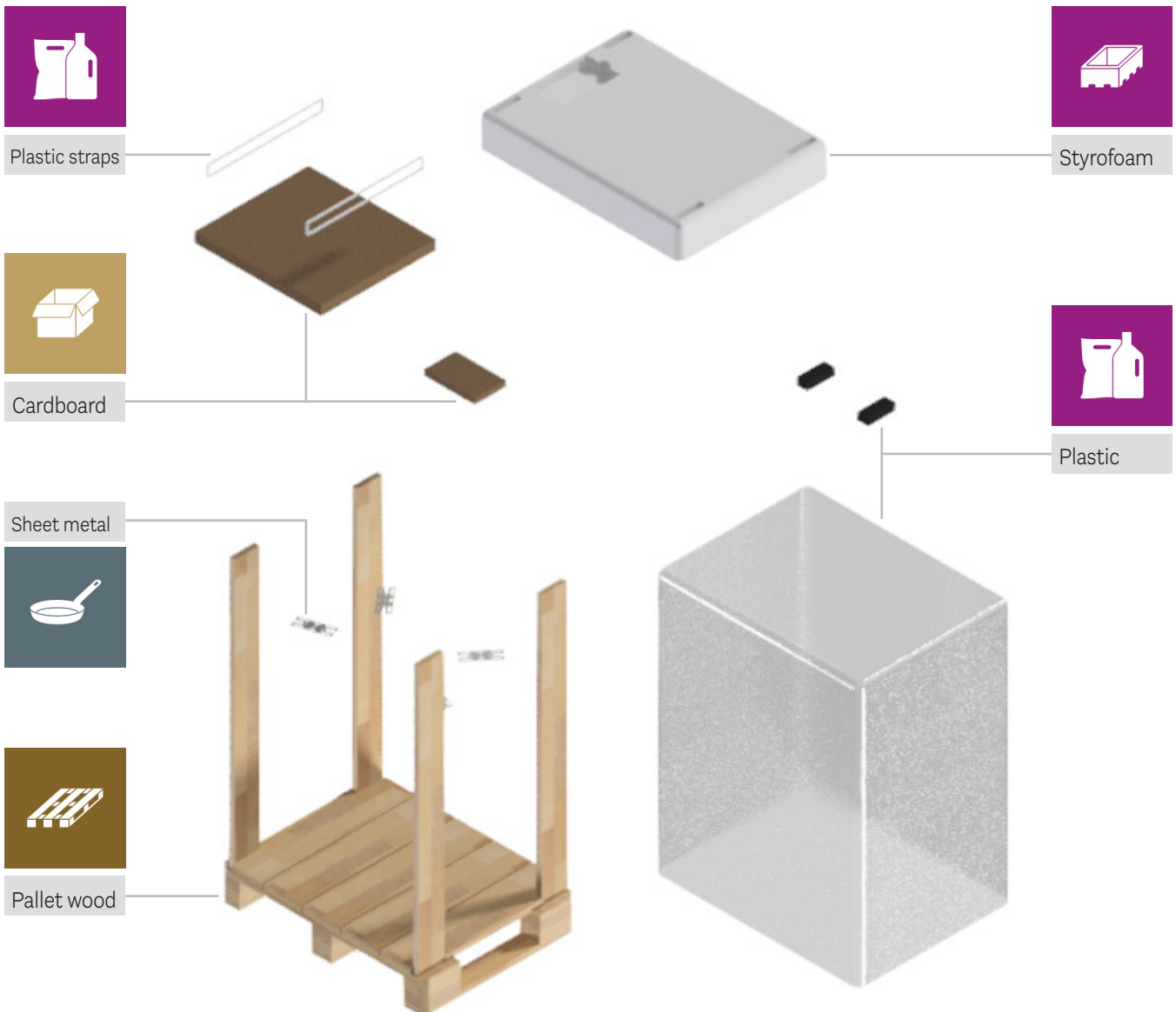

**DISPOSAL AFTER END OF LIFE**

When your fireplace can no longer be used in the distant future, it is important that it is disposed of correctly. At the end of the user manual you will find an overview of how to dispose of the fireplace itself at the end of its service life.



**PACKAGING AT DELIVERY**

The product comes attached to a transport pallet and is clamped with screws that need to be removed.

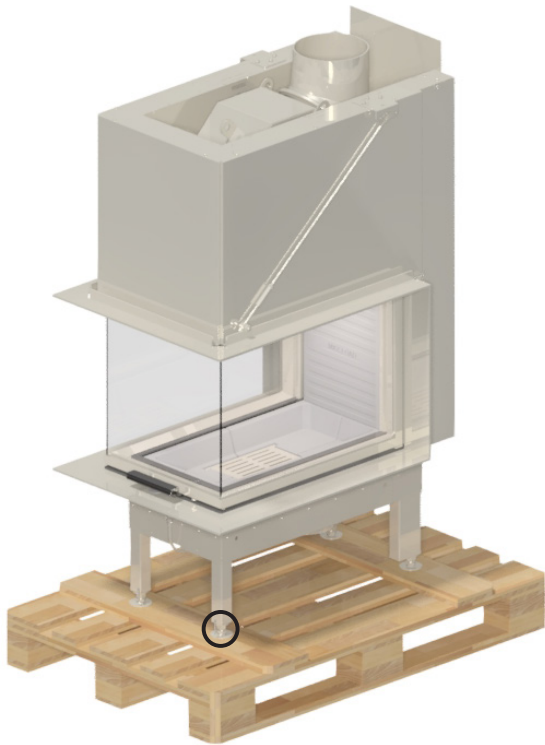

**HEIGHT ADJUSTMENT**

There are four adjustment screws underneath the appliance. Make sure the fireplace is level by using the adjustment screws.



**REFLECTOR PLATE**

The fireplace is supplied with a reflector plate on the back. If the system has a rear outlet instead of a top outlet, the reflector plate must be removed.



**TRANSPORT LOCK**

On delivery, the door is locked for transport and must be released before installation. This is done by removing the transport screws in the counterweights.



**CHANGING THE FLUE OUTLET DIRECTION**

The stove comes with a 200 mm diameter flue outlet.

The flue outlet can be changed from top outlet to rear outlet or vice versa. Loosen the clamping band on the outlet spout and adjust as desired.

**ATTENTION!**

If the stove is installed with a rear outlet to the chimney, the back wall must be non-combustible (e.g. brick).

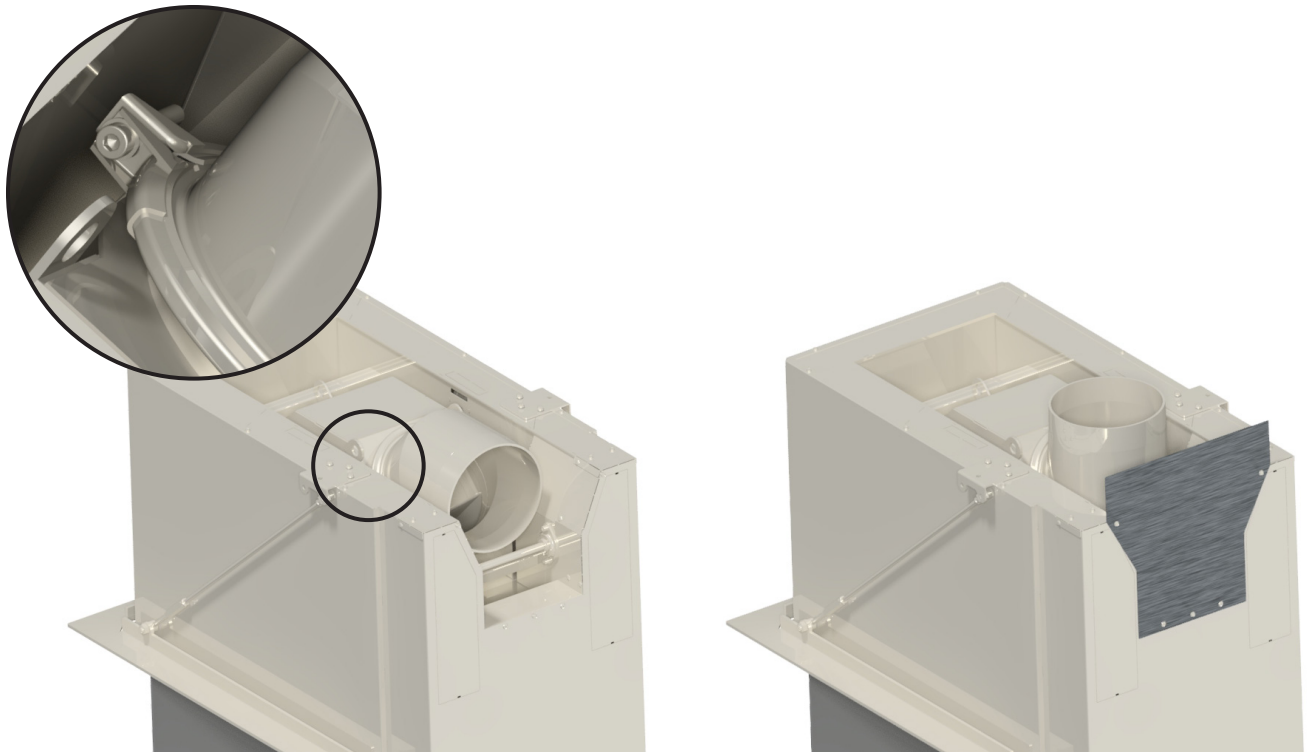

### REMOVING THE COMBUSTION CHAMBER LINING

To gain access to the flue, carefully remove the two lower flue baffle plates and the four upper flue baffle plates. Carefully remove the lower flue baffle plates by pushing the back side upwards. Then lower the front side and carefully remove. The upper flue baffle plates rest on a bracket; push them forward, tilt and lower them to remove them. Then carefully reinsert them in reverse order.

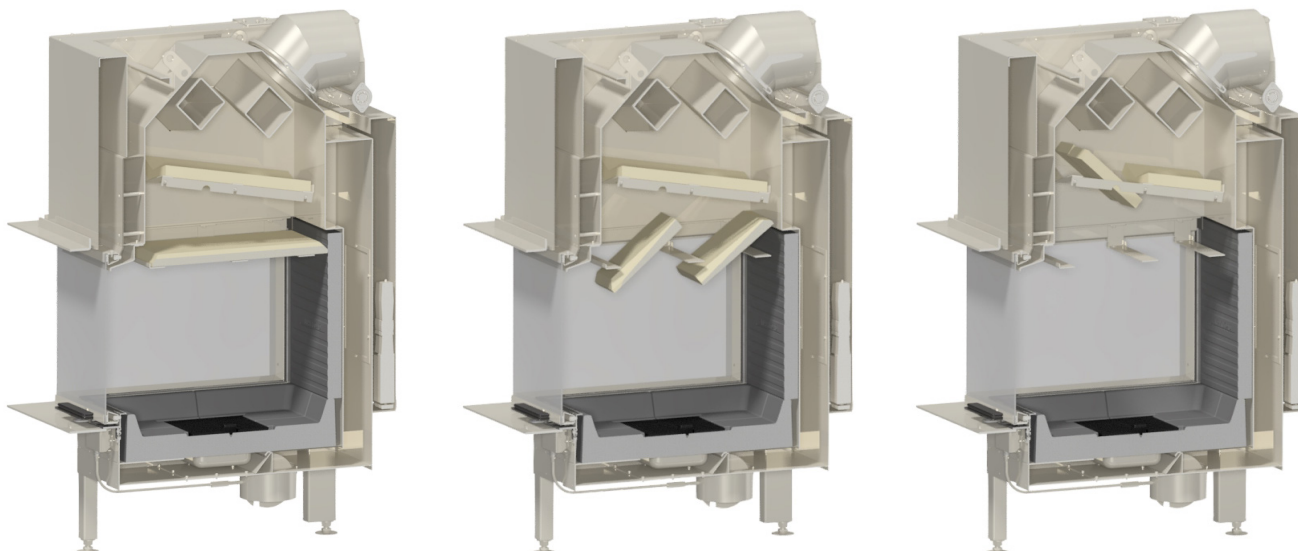

Remove the lower flue baffle plates carefully by pushing the back side upwards. Then lower the front side and carefully remove

The upper flue baffle plates rest on a bracket; push them forward, tilt and lower them to remove them.



#### ATTENTION!

Take care when putting back the smoke deflector plates.

### CLEANING AND MAINTENANCE

It is important that the fireplace is cleaned and maintained both inside and out. When this is done, the fireplace must be cold. The fireplace should be inspected by a chimney sweep once a year. Always check the chimney and flue collar for blockages before a heating season. Inspect the exterior and interior of the fireplace for damage, especially gaskets and the thermal insulation plates (vermiculite).

The combustion chamber lining protects the fireplace insert from heat from the fire. Due to the large temperature variations, cracks may appear in the combustion chamber lining. These can last for several years and should be replaced if they start to crack. The plates are loosely placed inside the combustion chamber and can easily be replaced by you or your dealer. For detailed instructions on how to replace the plates or remove them to clean the flue, see the user manual.

Lubricate the door rails and their bearings as needed with lubricating spray, but it is important to lubricate continuously so that it is not only done when the damage has occurred. After lubrication, move the door up and down 10-15 times and lubricate again to ensure that it gets into the bearings. The brackets for opening the glass should also be lubricated continuously. We recommend that our lubrication spray is used exclusively, as the use of other products can lead to the formation of odours and residues. Contact your dealer to get the lubricant.

**SERVICE HATCH**

The damper lever and damper wire can be accessed through the service hatch at the bottom of the firebox. Remove the combustion chamber liner and remove the service plate. There is now access to the damper and damper wire under the combustion chamber.

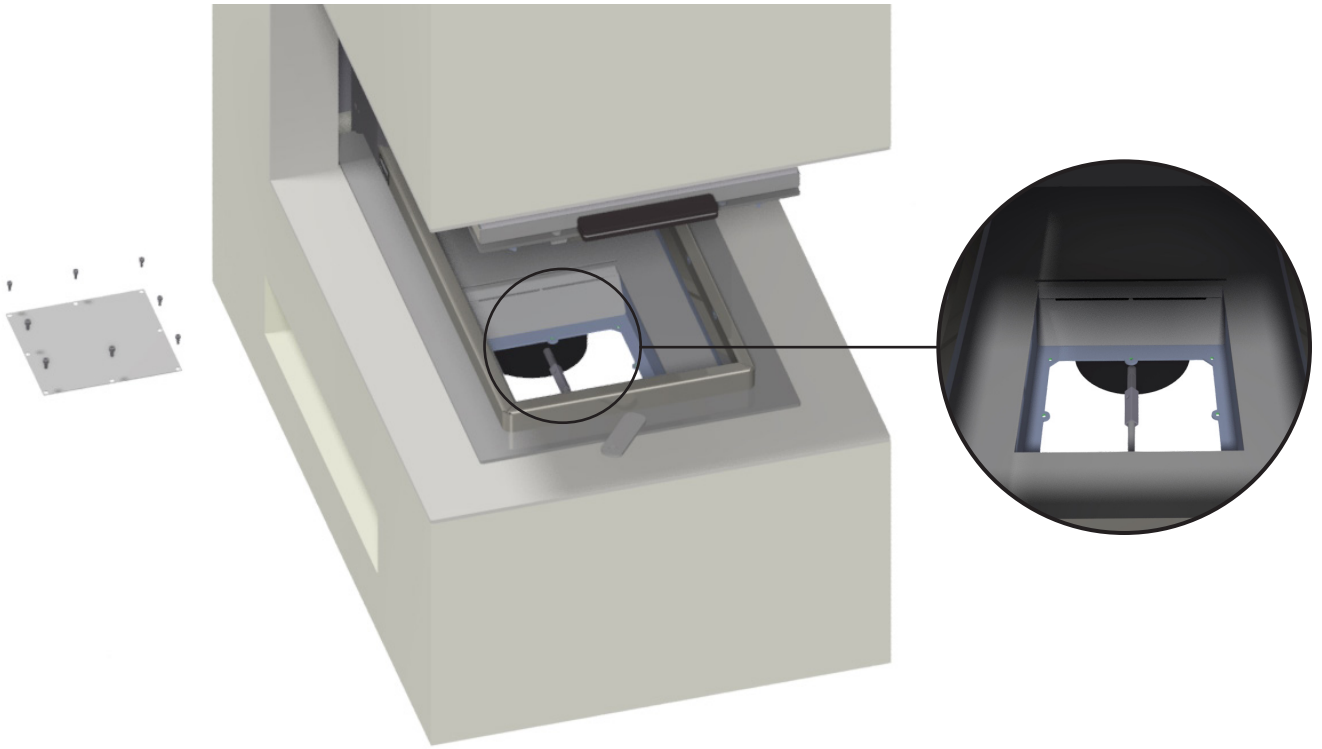

**HEAT DISTRIBUTOR**

By installing a heat distributor unit above the fireplace insert, heat can be 'transported' to other rooms.

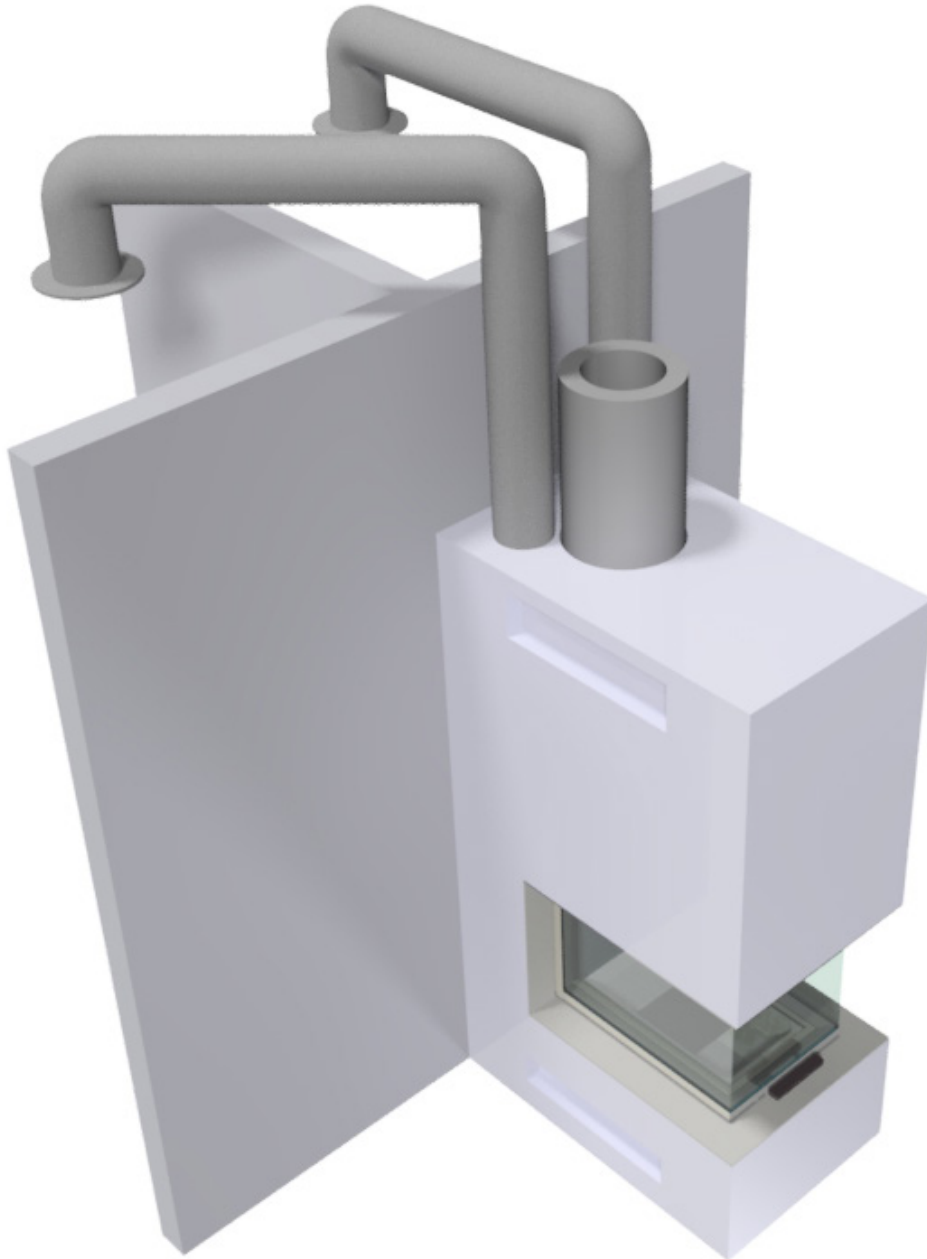

**INSTALLATION DIMENSIONS**

To ensure a correct and durable installation, the fireplace insert must not be installed too tightly. During heating, the fireplace insert expands and if there is not enough space, both the insert and the brickwork can be damaged. Therefore, always follow the installation dimensions carefully.

The fireplace insert comes with or without frames. Never lift the frames as this can cause distortions that affect the function of the stove. Before installing the insert, make sure that the door closes and opens correctly. If the door does not function properly, it may require a full dismantling of the installation to correct the error.

If you are installing the insert with a built-in frame, there must be an air gap of at least 5 mm above the top frame. This air gap is necessary so that the stove can expand during use. It is very important that the frame does not bear any weight from the build-in. If the gap is missing, it can lead to damage to both the stove and the brickwork.

RAIS/Attika cannot be held responsible for incorrect installation and lack of air gap and the warranty is void.

**NO TAPE ON THE FRAMES**

Under no circumstances should tape be applied to the frames, as this will damage the paintwork. RAIS/Attika accepts no responsibility for damage caused by the use of tape.

**CONVECTION VENTS**

There is a minimum requirement for the convection air area. This area must be respected due to the risk of overheating and distance to combustible material. Make sure that the stove can draw convection air under the stove and exhaust it above the stove. There must be a non-combustible top plate in the cabinet just above the upper convection outlet.

There must always be convection openings of the mentioned sizes above and below the stove. The convection areas can be distributed by using different convection grates.

If the convection areas are not observed, RAIS/Attika cannot be held liable for any damage to the stove and the warranty will be cancelled.

**CHOICE OF MATERIAL FOR INSTALLATION**

The material can be panels/brick with an insulation value greater than  $0.03 \text{ m}^2 \times \text{K/W}$ . The insulation is defined as wall thickness (in metres) divided by the wall's Lambda value. Consult your installation technician/chimney inspector.

The installation drawings are based on a non-combustible building board enclosure made of 50 mm calcium silicate (Skamotec 225). The fireplace insert must be placed on heat-resistant material.

**IMPORTANT**

As a minimum, the chimney must be constructed of T400-N1-D-50050-G100 flue pipe.



CONVECTION AREAS	DIMENSIONS IN CM <sup>2</sup>
Above fireplace insert	700
Below fireplace insert	530

ENG



**INSTALLATION DIMENSIONS: WITHOUT FRAME**

Minimum cavity dimensions (H x W x D) 477 x 528 x 705 mm. A fireplace insert must never be tightly inserted into a cavity, as steel expands when heated.

**IMPORTANT**

The cavity dimension is the minimum finished dimension. Therefore, remember to take into account plastering and the general structure of the wall so that the dimensions are respected.



The internal dimensions of the installation box must be at least (height x width x depth) 1800 x 528 x 914 mm.

There must be a minimum convection air intake of 530 cm<sup>2</sup> underneath the fireplace and 700 cm<sup>2</sup> above it. The minimum convection-air areas above and below the fireplace can be distributed over several holes. There must be a minimum distance of 420 mm from the top convection outlet to a combustible ceiling.

A non-combustible plate must be placed directly above the convection opening to prevent "standing" hot air. This is done to protect the ceiling and direct hot air from the cassette.

The flue pipe must be insulated along the entire length inside the installation box and when it passes the non-combustible plate at the top. It is important that all joints between the chimney and the installation box are properly sealed to prevent hot air from escaping.

**ATTENTION!**

The insulated chimney must extend all the way to the flue outlet adapter. Also applies if a ben- ded pipe is used into an existing chimney.

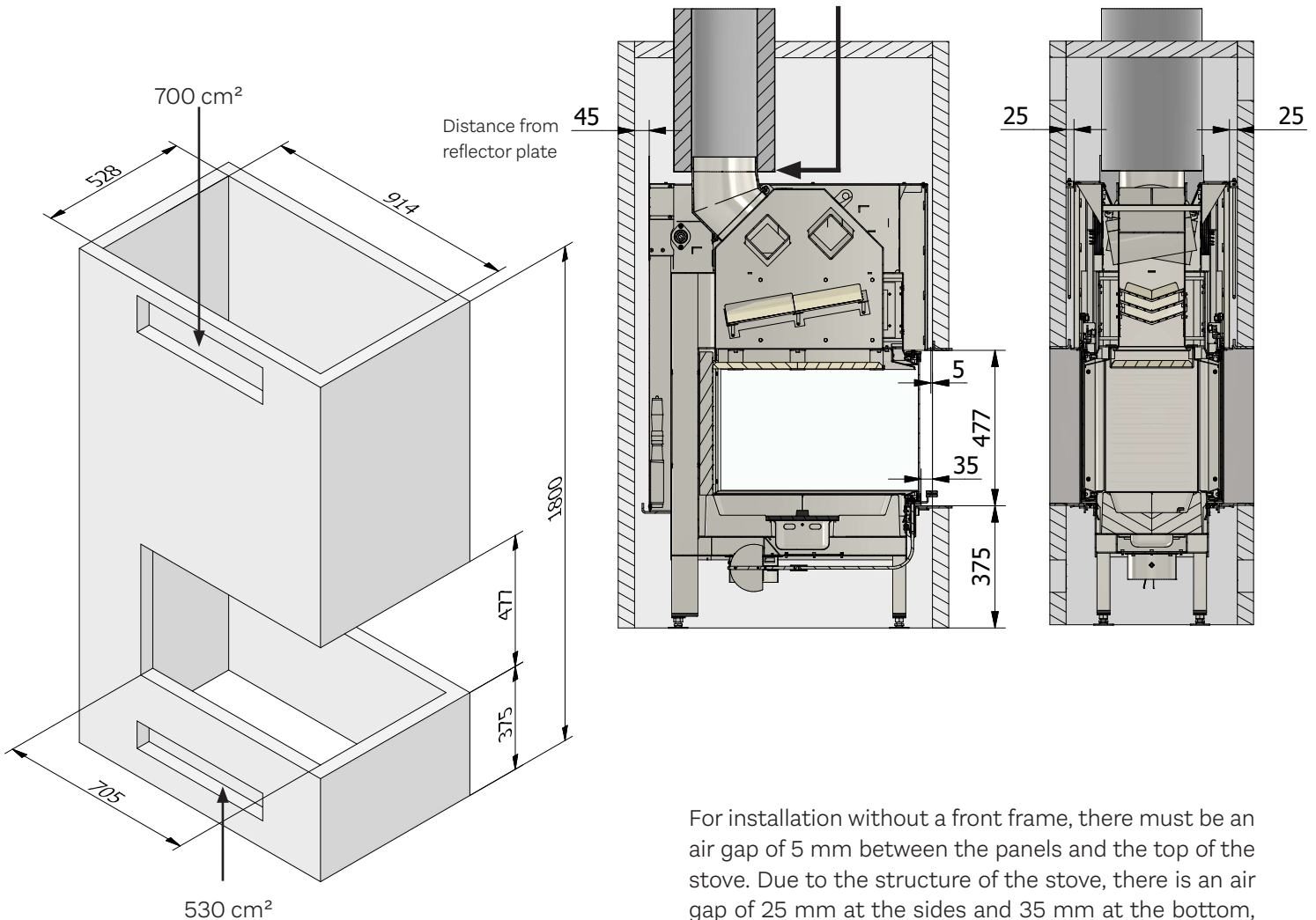

For installation without a front frame, there must be an air gap of 5 mm between the panels and the top of the stove. Due to the structure of the stove, there is an air gap of 25 mm at the sides and 35 mm at the bottom, which can be closed off with, for example, non-com- bustible panel pieces.

**INSTALLATION DIMENSIONS: WITH FRAME**

Hole dimensions for flush mounting with wall (height x width x depth) min. 495 x 528 x 705 mm. A fireplace insert must never be tightly inserted into a cavity, as steel expands when heated.

**IMPORTANT**

The cavity dimension is the minimum finished dimension. Therefore, remember to take into account plastering and the general structure of the wall so that the dimensions are respected.



The internal dimensions of the installation box must be at least (height x width x depth) 1800 x 528 x 924 mm.

There must be a minimum convection air intake of 530 cm<sup>2</sup> underneath the fireplace and 700 cm<sup>2</sup> above it. The minimum convection-air areas above and below the fireplace can be distributed over several holes. There must be a minimum distance of 420 mm from the top convection outlet to a combustible ceiling.

A non-combustible plate must be placed directly above the convection opening to prevent "standing" hot air. This is done to protect the ceiling and direct hot air from the cassette.

The flue pipe must be insulated along the entire length inside the installation box and when it passes the non-combustible plate at the top. It is important that all joints between the chimney and the installation box are properly sealed to prevent hot air from escaping.

**ATTENTION!**

The insulated chimney must extend all the way to the flue outlet adapter. Also applies if a ben- ded pipe is used into an existing chimney.



**ATTENTION!**

Under no circumstances should the frame bear any weight from the installation or be lifted in.

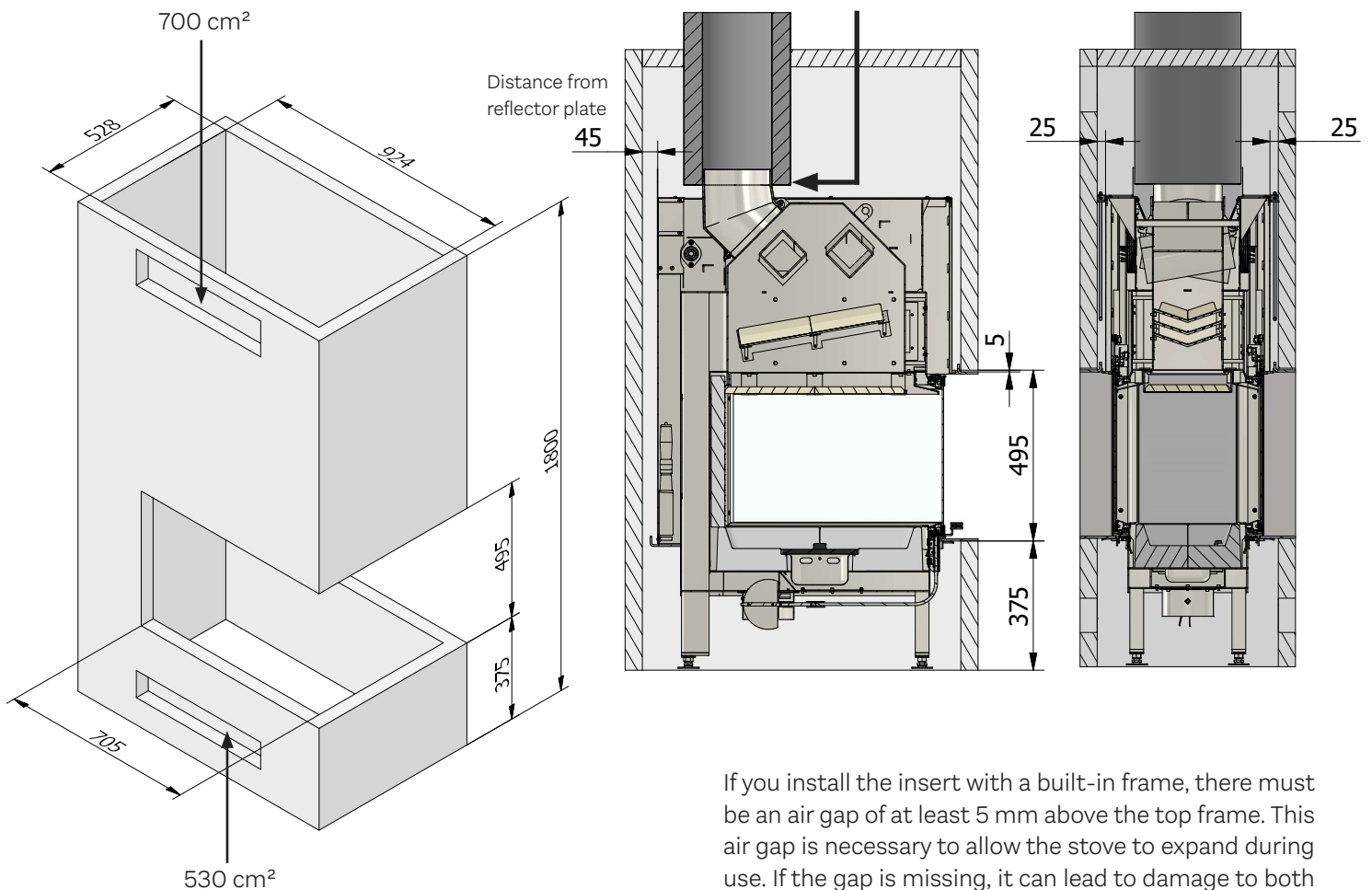

If you install the insert with a built-in frame, there must be an air gap of at least 5 mm above the top frame. This air gap is necessary to allow the stove to expand during use. If the gap is missing, it can lead to damage to both the stove and masonry.

**DISTANCE TO FLAMMABLE MATERIAL WITH WALL MOVED FORWARD**

If a combustibile wall is moved forward, the first 375 mm must be made of a non-combustible material, e.g. 50 mm Skamotec 225. The wall may only be moved forward to the rear of the vertical frames. When installing a stove without frames, there must be at least 670 mm from the front of the frame under the door to the wall.

With frame

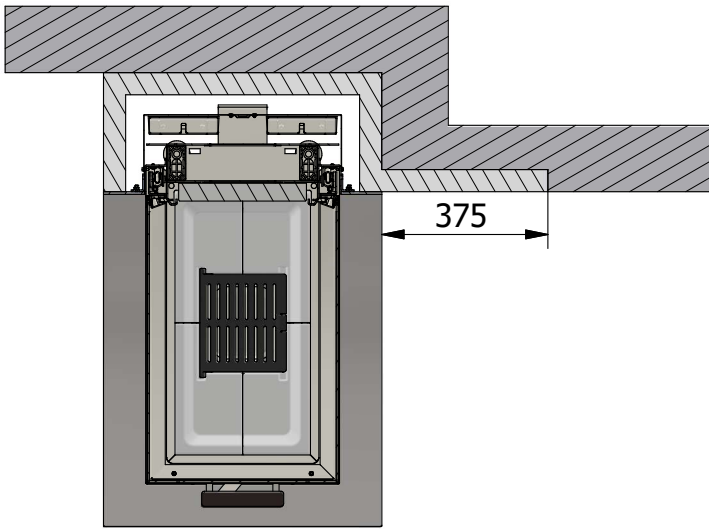

Without frame

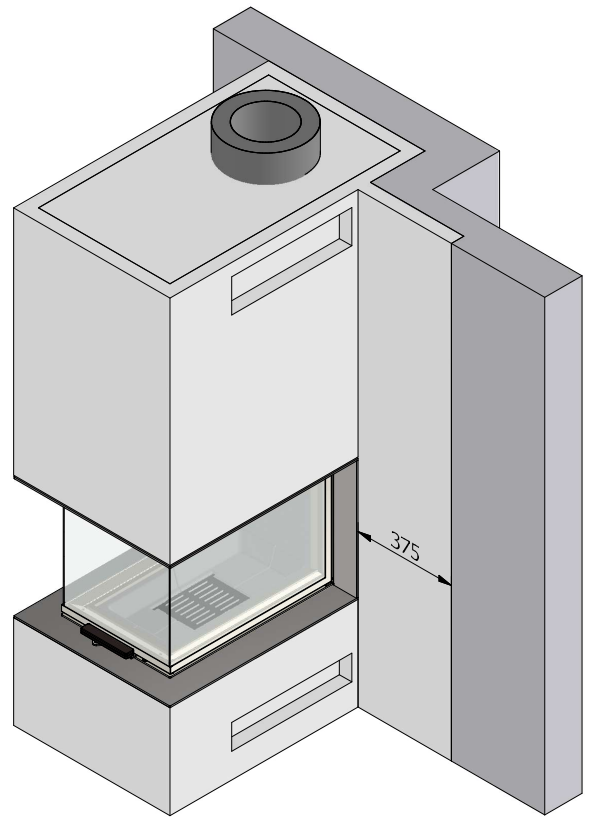
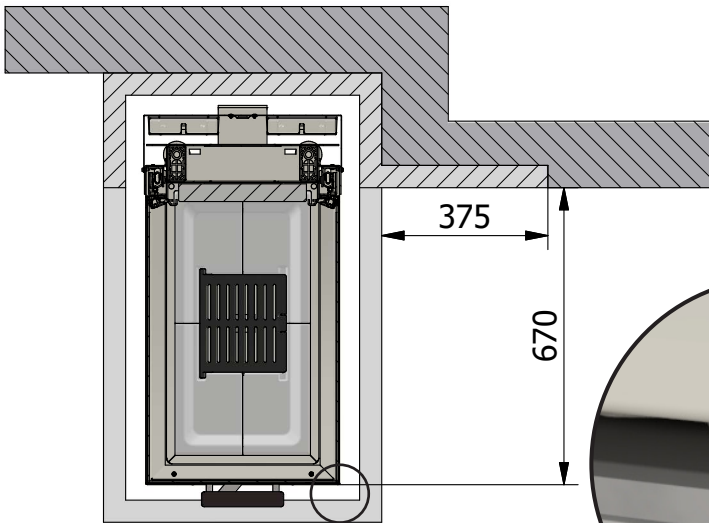

The door is made self-closing by removing part of the door counterweight. The counterweight is located on the back of the appliance.



1. Using a 13 mm spanner, remove the transport lock for the counterweight on both sides.

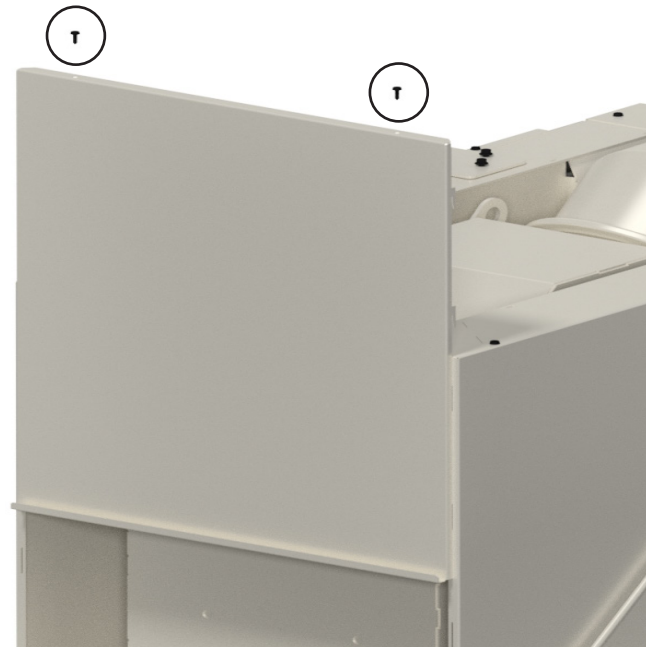

2. Remove the front cover by removing the two screws on the top with a 7 mm spanner and pulling the cover upwards.

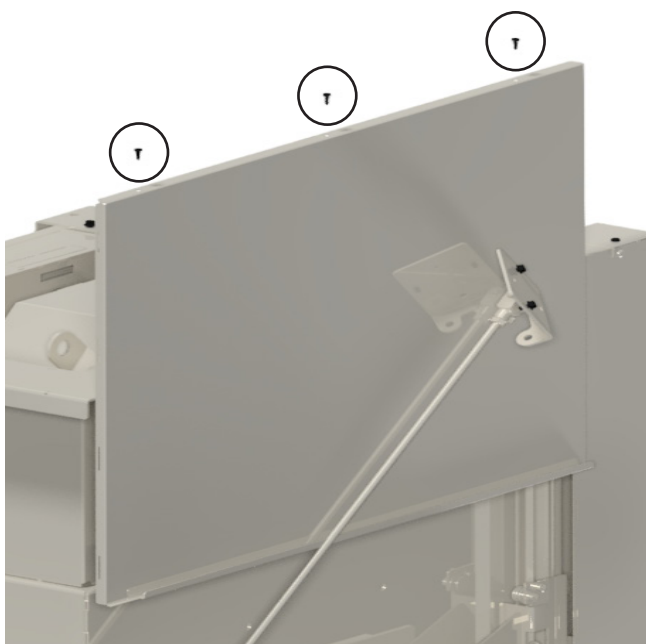

3. First remove the screws that secure the anchor plate for the adjustment shaft to the frame using an 8 mm spanner. Then remove the screws for the cover using a 7 mm spanner and pull the cover upwards.

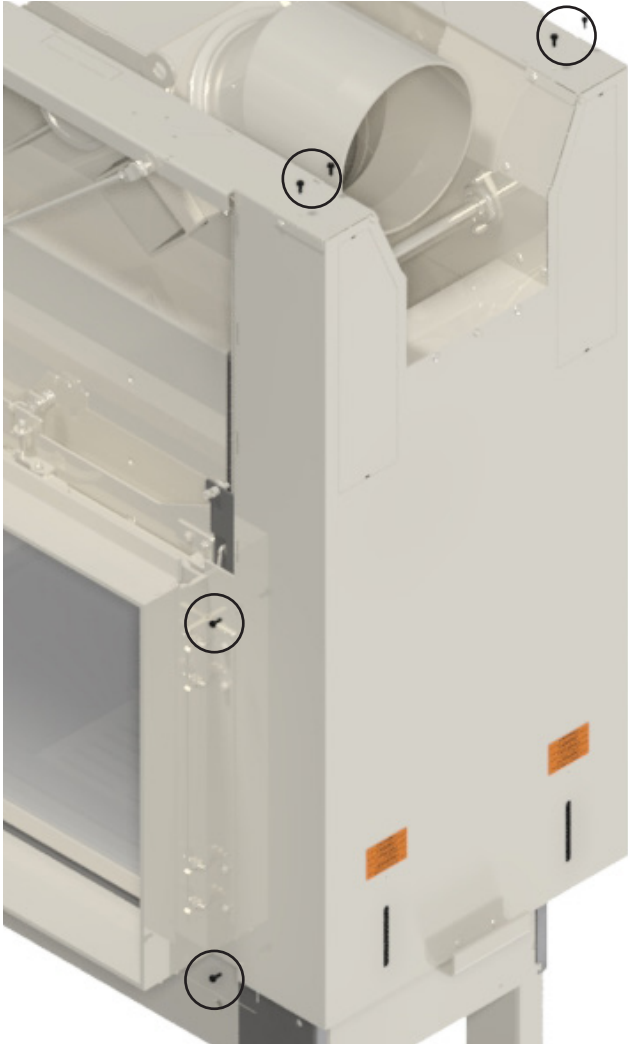

4. Remove the counterweight cover on the rear by loosening the two screws on each side and the four screws at the top with a 7 mm spanner, then pull the cover backwards.

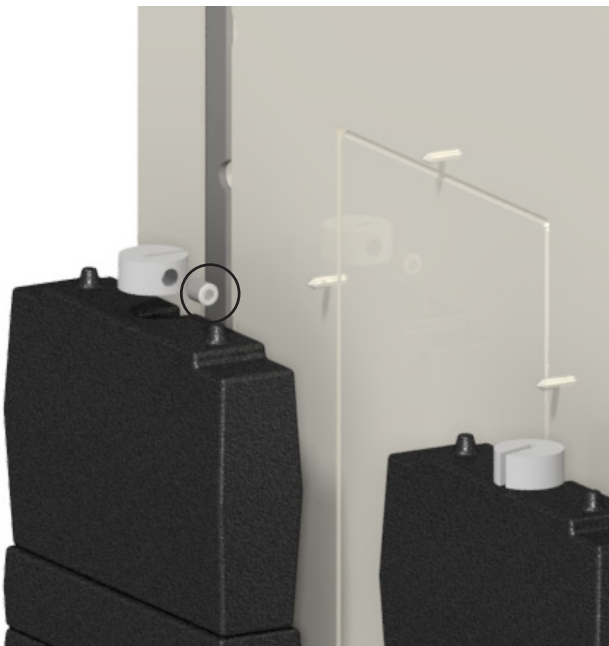

5. Use a 4 mm Allen key to loosen the M8 grub screw in the wire clamp. Remove the necessary number of counterweights so that the door closes slowly and at a constant speed. Finish by checking that the function is working correctly.

Refit the covers in reverse order.

## CONVERT TO SELF-CLOSING DOOR AFTER BUILDING IN THE INSERT

The door is made self-closing by removing part of the door counterweight. The counterweight is located on the back of the appliance.

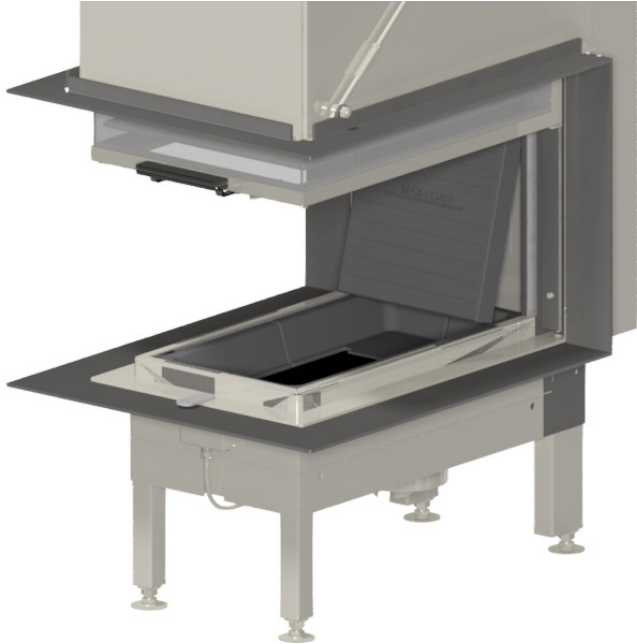

1. Remove the vermiculite plate at the rear of the combustion chamber by pulling it out at the bottom to access the service opening.

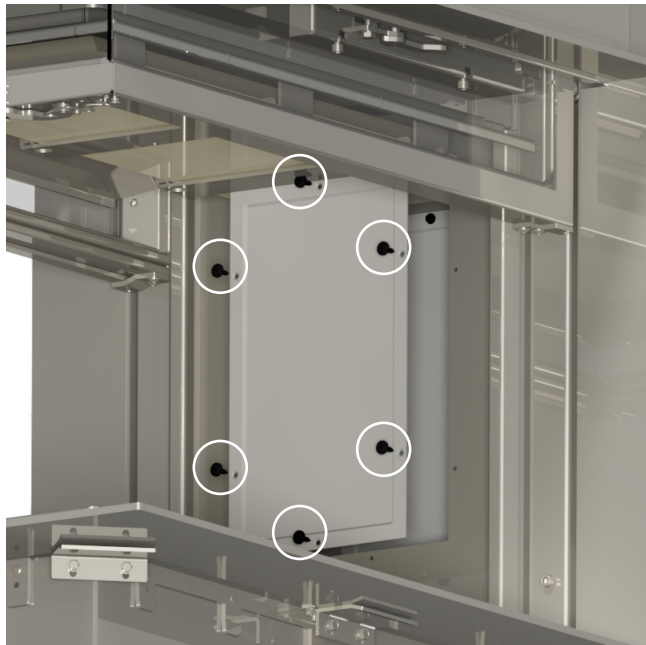

2. Remove the six screws securing the outer service door.

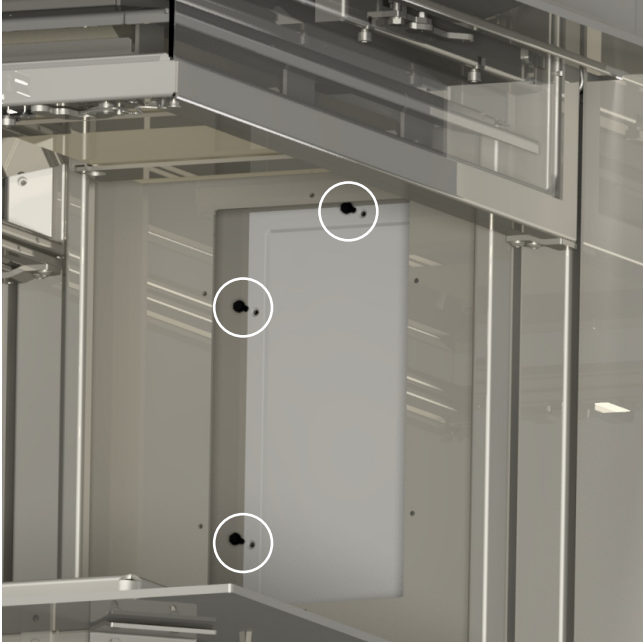

3. Remove the six screws securing the inner service door.



4. Use a 4 mm Allen key to loosen the M8 grub screw in the wire clamp. Remove the necessary number of counterweights so that the door closes slowly and at a constant speed. Finish by checking that the function is working correctly.

Wire clamps, service panels and vermiculite plate are refitted in reverse order.

When the fireplace insert is installed in a construction where direct combustion air is required, external air must be connected to the fireplace from the outside. All RAIS/attika fireplaces have the option to supply external air.

This external air supply is what we call AirSystem. The air intake for the system can be hidden by installing it either in the floor or in the wall behind the fireplace.

To ensure that the AirSystem works, it is important to ensure that no negative pressure can build up in the home. It is also important that the convection openings are not blocked.

The maximum length of the flex hose is 5 metres. It is important that it is not bent and folded around corners so that the tube collapses and the airflow cannot get through as intended.

If the air supply is 5-10 metres from the fireplace, use a Ø180 mm flex hose instead.



**PERMANENT AIR SUPPLY**

The appliance needs a permanent air supply to the room of installation as the appliance is over 5kW, confer with Building regulation Approved Document J.

Permanently open air vents should be non-adjustable, sized to admit sufficient air for the purpose intended and positioned where they are unlikely to become blocked. see Approved Document J.

A CO Alarm must be fitted into the same room as the appliance upon installation. The alarm shall be compliant with British Standards BS 50291. Where battery powered alarms are selected, alarms with 'sealed for life' batteries rather than alarms with replaceable batteries are the better option.

**THE CLEAN AIR ACT 1993 AND SMOKE CONTROL AREAS**

Under the clean air act local authorities may declare the whole or part of the district of the authority to be a smoke control area. It is an offence to emit smoke from a chimney of a building, from a furnace or from any fixed boiler if located in a designated smoke control area. It is also an offence to acquire an "unauthorised fuel" for use within a smoke control area unless it is used in an "exempt" appliance ("exempted" from the controls which generally apply in the smoke control area).

In England appliances are exempted by publication on a list by the secretary of state in accordance with changes made to sections 20 and 21 of the clean air act 1993 by section 15 of the deregulation act 2015. In Scotland appliances are exempted by publication on a list by Scottish ministers under section 50 of the regulatory reform (Scotland) act 2014. Similarly, in Northern Ireland appliances are exempted by publication on a list by the department of agriculture, environment and rural affairs under section 16 of the environmental better regulation act (Northern Ireland) 2016. In Wales appliances are exempted by regulations made by Welsh ministers.

The secretary of state for environment, food and rural affairs has powers under the act to authorize smokeless fuels or exempt appliances for use in smoke control areas in England. In Scotland and Wales this power rests with the ministers in the devolved administrations for those countries. Separate legislation, the clean air (Northern Ireland) order 1981, applies in Northern Ireland. Therefore it is a requirement that fuels burnt or obtained for use in smoke control areas have been "authorised" in regulations and that appliances used to burn solid fuel in those areas (other than "authorised"

fuels) have been exempted by an order made and signed by the secretary of state or minister in the devolved administrations.

The Visio 3:1 (All variants) have been recommended as suitable for use in smoke control areas when burning wood logs.

**FUEL OVERLOADING**

The maximum amount of fuel specified in this manual should not be exceeded, overloading can cause excess smoke.

**REFUELLING ON TO A LOW FIRE BED**

If there is insufficient burning material in the firebed to light a new fuel charge, excessive smoke emission can occur. Refuelling must be carried out onto a sufficient quantity of glowing embers and ash that the new fuel charge will ignite in a reasonable period. If there are too few embers in the fire bed add suitable kindling to prevent excess smoke.

**DAMPERS LEFT OPEN**

Operation with the air control or appliance dampers open can cause excess smoke. The appliance must not be operated with air controls, appliance dampers or door left open except as directed in the instructions.

**OPERATION WITH DOOR LEFT OPEN**

Operation with the door open can cause excess smoke. The appliance must not be operated with the appliance door left open except as directed in the instructions.

**ATTENTION!**

This page is only relevant for appliances installed in United Kingdom.



Article number: 1236520ENG



5 708252 444843

**RAIS**<sup>®</sup>

RAIS A/S  
Industrivej 20  
DK-9900 Frederikshavn  
Denmark  
[www.rais.com](http://www.rais.com)

**attika**<sup>®</sup>  
FEUERKULTUR

ATTIKA FEUER AG  
Brunnmatt 16  
CH-6330 Cham  
Switzerland  
[www.attika.ch](http://www.attika.ch)